



Australian Representatives

ROJONE, PTY LTD.

Tel: 02 9829 1555

E: sales@rojone.com.au

www.rojone.com.au

Waterproof Bulkhead-Mounted RF Connectors



Drawing on long experience in designing RF connectors for the demanding requirements of military field radio systems, we have developed a unique system of sealing that makes connectors completely waterproof, inside and out—without expensive soldered hermetic seals or separate caps.

Our sealing system also offers enhanced electrical performance compared to hermetically-sealed connectors.

Pressure testing before shipping guarantees the integrity of the connector seals.

The connectors in this brochure are only an indication of our capabilities—virtually any bulkhead-mounted connector in our catalog can be manufactured as a waterproof type.

Contents

| | |
|-------------------------|---|
| BNC | 2 |
| SMA | 3 |
| SMB | 4 |
| TNC | 5 |
| F Series | 6 |
| Adapters Between Series | 6 |
| About AEP | 7 |



APPLIED ENGINEERING PRODUCTS

104 John W. Murphy Drive • P.O. Box 510 • New Haven, CT 06513

(203) 776-2813 • FAX (203) 776-8294

www.aepconnectors.com • e-mail: aepsales@aepconnectors.com

BNC Waterproof Bulkhead Connectors

Straight Cable Jack

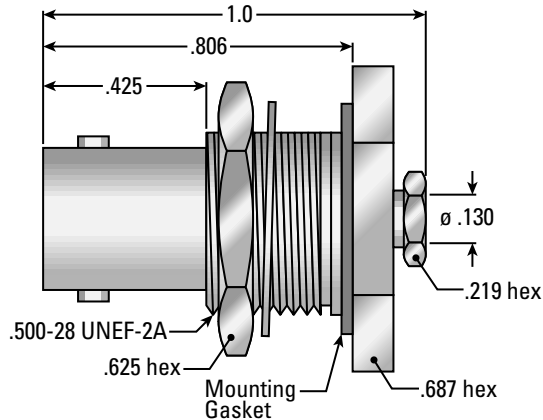
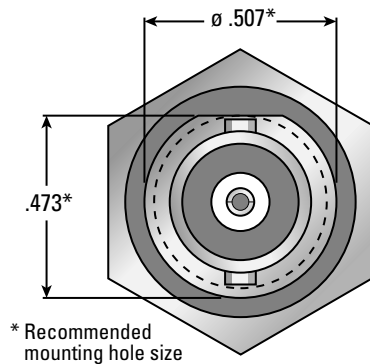

Drawing ≈
2X actual size.

AEP Part Number: 6501-7551-219

Characteristics:

- Brass body, nickel plated.
- Beryllium-copper captive contact, gold plated.
- Clamp-type hardware for Times RD-316 cable.
- Waterproof to 1 meter for 30 minutes.
- Meets MIL-PRF-39012 requirements.

Options:

- Silver or gold plated body.
- Crimp attachment for flexible cable, or solder-clamp for semi-rigid cable.
- Available for most RG, M17, or semi-rigid cables up to .215 outer diameter.

Right Angle Cable Jack

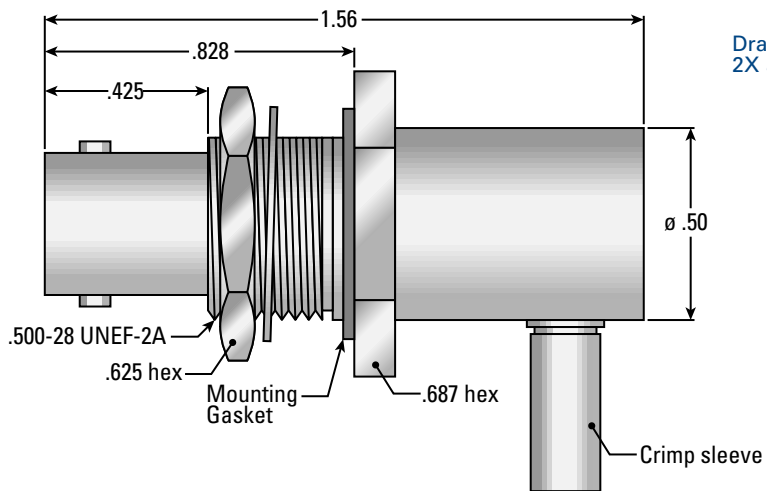
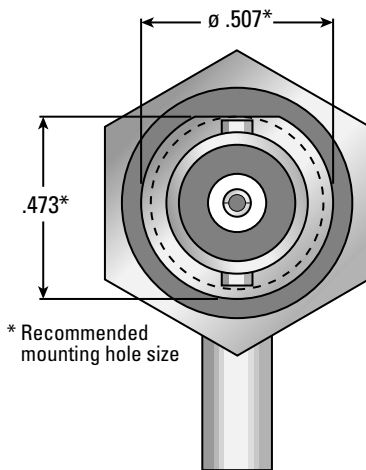

Drawing ≈
2X actual size.

AEP Part Number: 6561-6521-003

Characteristics:

- Brass body, silver plated.
- Beryllium-copper captive contact, gold plated.
- Crimp-type hardware for RG-316 cable.
- Meets MIL-PRF-39012 requirements.

Options:

- Nickel or gold plated body.
- Clamp attachment for flexible cable, or solder-clamp for semi-rigid cable.
- Available for most RG, M17, or semi-rigid cables up to .215 outer diameter.



SMA Waterproof Bulkhead Connectors

Straight Cable Jack—Standard Mating

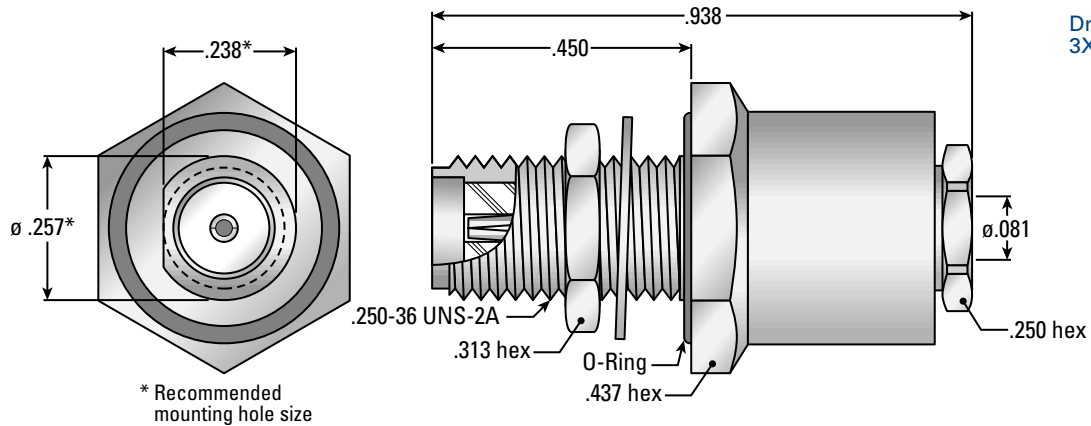

AEP Part Number: 9153-7553-002

Characteristics:

- Stainless steel body, nickel plated.
- Beryllium-copper captive contact, gold plated.
- Clamp-type hardware for RG-178 cable.
- Meets MIL-PRF-39012 requirements.

Options:

- Gold plated or passivated body.
- Crimp attachment for flexible cable, or solder-clamp for semi-rigid cable.
- Available for most RG, M17, or semi-rigid cables up to .215 outer diameter.

Straight Cable Jack—Polarized Mating

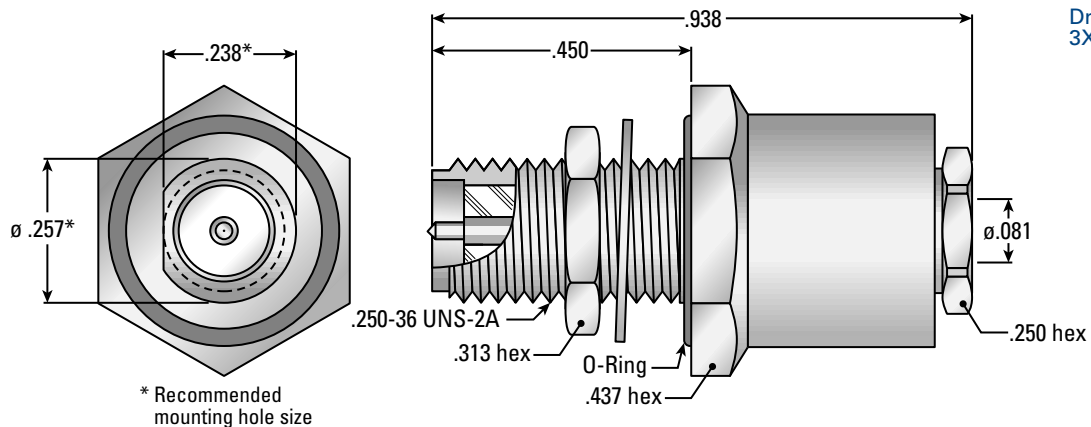

AEP Part Number: 9731-1553-002

Characteristics:

- Stainless steel body, gold plated.
- Beryllium-copper captive contact, gold plated.
- Clamp-type hardware for RG-178 cable.

Options:

- Nickel plated or passivated body.
- Crimp attachment for flexible cable, or solder-clamp for semi-rigid cable.
- Available for most RG, M17, or semi-rigid cables up to .215 outer diameter.



SMB Waterproof Bulkhead Connectors

Straight Cable Jack—Hex Mounting Nut

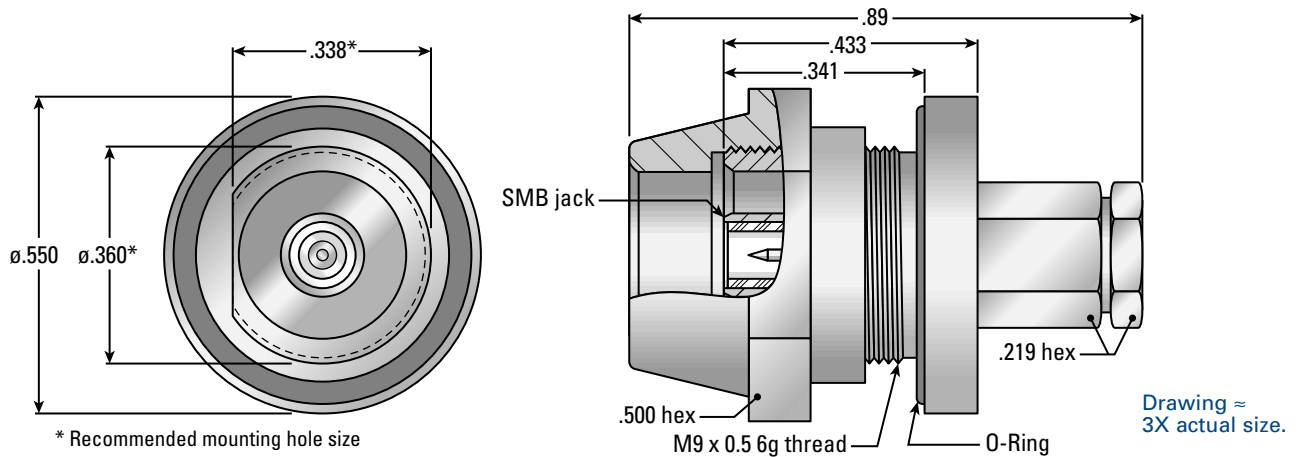

AEP Part Number: **2027-3551-403**

Characteristics:

- Brass body body, flat black chrome plated.
- Beryllium-copper captive contact, gold plated.
- Clamp-type hardware for RG-316 cable.
- Hood over mating end to prevent mismatching.
- Waterproof to 3 PSI pressure.

Options:

- Gold or nickel plated body.
- Crimp attachment for flexible cable, or solder-clamp for semi-rigid cable.
- Available for most RG, M17, or semi-rigid cables up to .125 outer diameter.

Straight Cable Jack—Spanner Mounting Nut

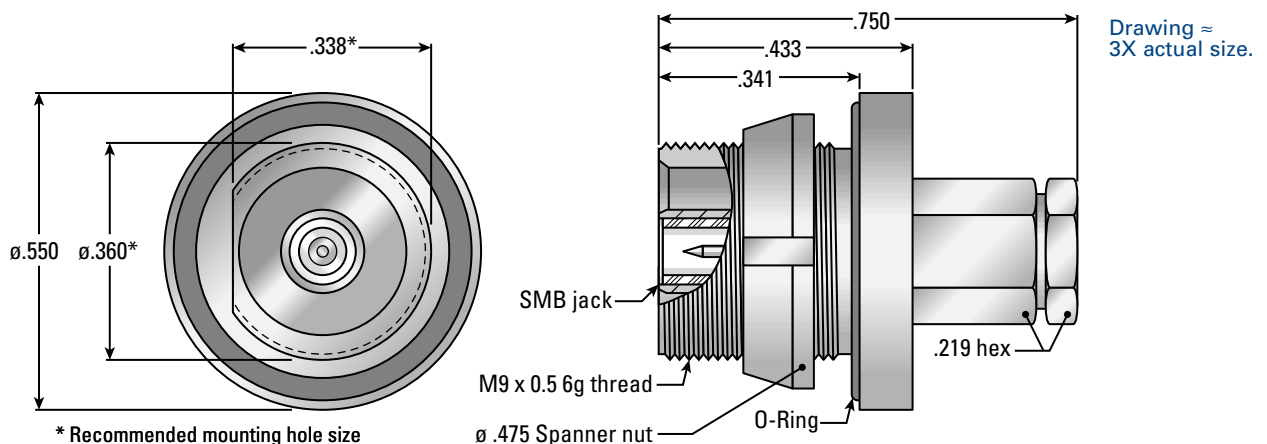

AEP Part Number: **2027-3551-303**

Characteristics:

- Brass body body, flat black chrome plated.
- Beryllium-copper captive contact, gold plated.
- Clamp-type hardware for RG-316 cable.
- Hood over mating end to prevent mismatching.
- Waterproof to 3 PSI pressure.

Options:

- Gold or nickel plated body.
- Crimp attachment for flexible cable, or solder-clamp for semi-rigid cable.
- Available for most RG, M17, or semi-rigid cables up to .125 outer diameter.



TNC Waterproof Bulkhead Connectors

Straight Cable Jack

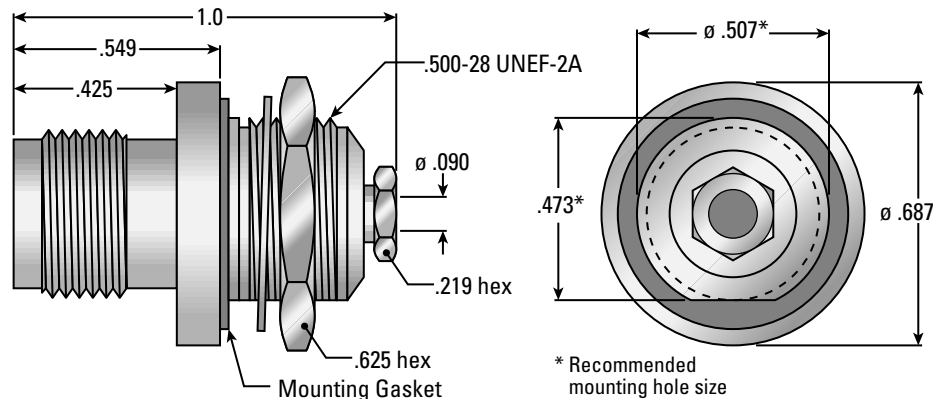

AEP Part Number: 6002-7551-202

Characteristics:

- Brass body, nickel plated.
- Beryllium-copper captive contact, gold plated.
- Clamp-type hardware for RG-178 cable.
- Meets MIL-PRF-39012 requirements.

Options:

- Silver or gold plated body.
- Crimp attachment for flexible cable, or solder-clamp for semi-rigid cable.
- Available for most RG, M17, or semi-rigid cables up to .215 outer diameter.

Straight Cable Jack

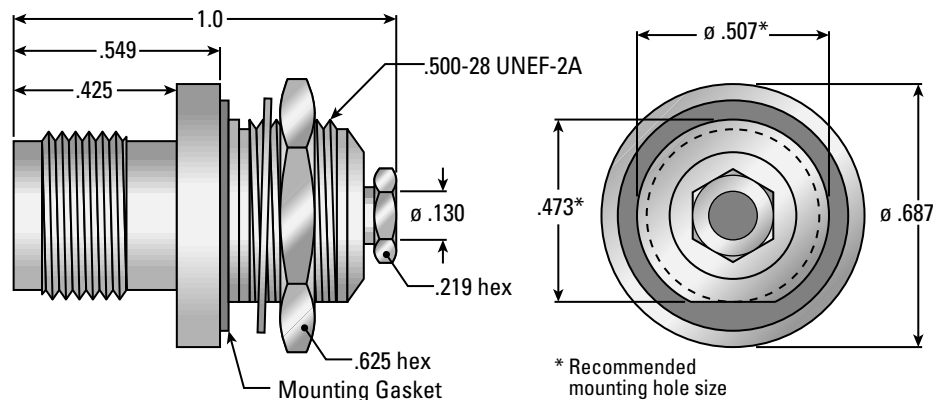

AEP Part Number: 6002-7551-219

Characteristics:

- Brass body, nickel plated.
- Beryllium-copper captive contact, gold plated.
- Clamp-type hardware for Times RD-316 cable.
- Waterproof to 1 meter for 30 minutes.
- Meets MIL-PRF-39012 requirements.

Options:

- Silver or gold plated body.
- Crimp attachment for flexible cable, or solder-clamp for semi-rigid cable.
- Available for most RG, M17, or semi-rigid cables up to .215 outer diameter.



Waterproof Bulkhead Connectors and Adapters

F Series Receptacle

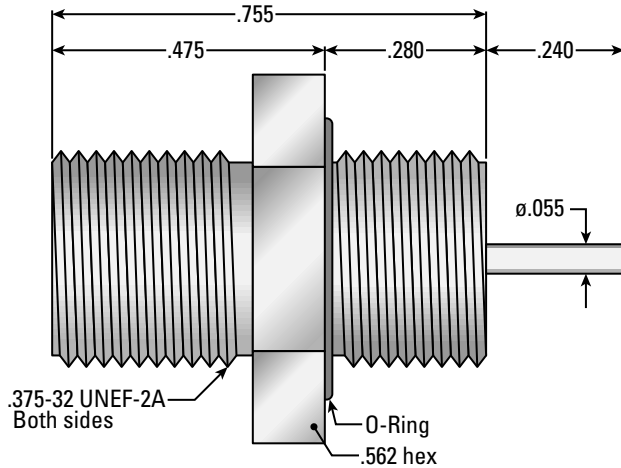

Drawing \approx
3X actual size.

AEP Part Number: 8572-7511-000

Characteristics:

- Brass body, nickel plated.
- Beryllium-copper captive contact, gold plated.
- Screw-in mounting.

Options:

- Gold or nickel plated body.
- Other contact termination types (tab, slotted, solder pot, threaded).

SMA to SSMC Adapter

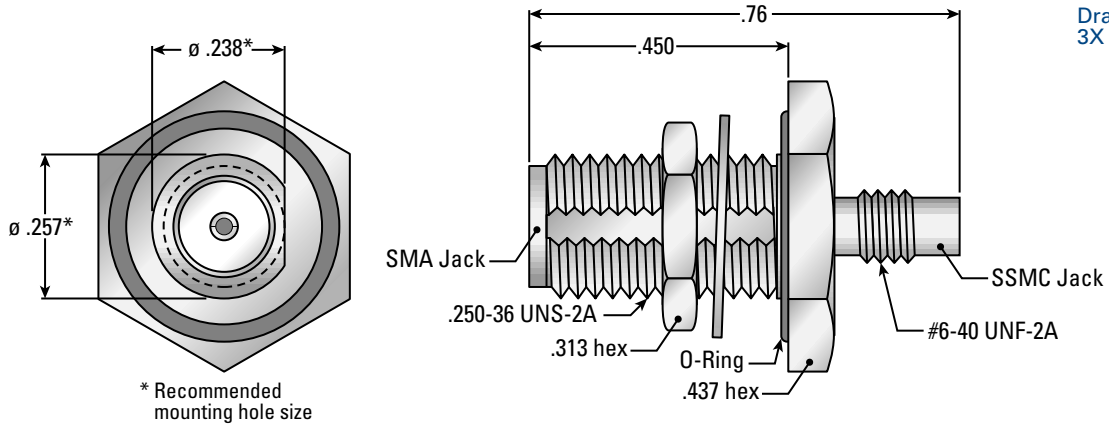

Drawing \approx
3X actual size.

AEP Part Number: 5944-1503-000

Characteristics:

- Stainless steel body, gold plated.
- Beryllium-copper captive contact, gold plated.
- Mates with SMA plug and SSMC plug.
- Meets MIL-PRF-39012 requirements.

Options:

- Nickel plated or passivated body.
- Other adapters within or between series in our catalog can be provided as waterproof types.



APPLIED ENGINEERING PRODUCTS

(203) 776-2813 • FAX (203) 776-8294

www.aepconnectors.com • aepsales@aepconnectors.com

About AEP

Since our foundation in 1973, we have always believed that having our customers take a look "inside AEP" is important in fostering strong vendor/customer relationships. We are proud of our physical plant and equipment, but even more so of our dedicated staff. When customers see first-hand how AEP's people keep a constant focus on maintaining and improving customer service and satisfaction, the reason for our consistently strong on-time delivery and quality records becomes clear.

We invite you to see for yourself. Call us to arrange a plant tour—or, if you can't make a visit, ask for your copy of *INSIDE AEP*, our facilities and capabilities brochure.



Other AEP Products

The waterproof connectors in this brochure are only part of our complete line of coaxial connectors and cable assemblies, including:

- BNC, N, and TNC connectors for miniature cables
- MCX and MMCX
- SMA
- SMB
- SMC
- SSMB
- SSMC
- SLB (Slide-on version of SMB)
- SLB/SA Self-aligning P.C. board receptacles
- SSLB (Slide-on version of SSMB)
- 75 ohm Miniature SMB
- 75 ohm Snap-on mating
- 75 ohm Screw-on mating
- Adapters within and between series
- Flexible cable assemblies
- Semi-rigid cable assemblies

Visit www.aepconnectors.com to see them all.



APPLIED ENGINEERING PRODUCTS

104 John W. Murphy Drive • P.O. Box 510 • New Haven, CT 06513
(203) 776-2813 • FAX (203) 776-8294
www.aepconnectors.com • aepsales@aepconnectors.com
ISO 9001 CERTIFIED

