

SMB Series Subminiature RF Connectors

ONLINE
CATALOG

Snap-on mating
Frequency range DC-4 GHz
Lightweight and economical



SLB and SMC connectors also shown for comparison



APPLIED ENGINEERING PRODUCTS

104 John W. Murphy Drive • P.O. Box 510 • New Haven, CT 06513

(203) 776-2813 • FAX (203) 776-8294

www.aepconnectors.com • e-mail: aepsales@aepconnectors.com

Australian Representatives
ROJONE, PTY LTD.
Tel: 02 9829 1555
E: sales@rojone.com.au
www.rojone.com.au

SMB Subminiature Connectors

Click on any line below to go directly to the appropriate page

Contents

Technical Information

Interfaces and specifications	2
Cable attachment methods	3

Cable Connectors

Straight plugs for flexible and semi-rigid cable	4
Right angle plugs for flexible and semi-rigid cable	4
Bulkhead mounted plugs for flexible and semi-rigid cable	5
Straight jacks for flexible and semi-rigid cable	6
Right angle jacks for flexible and semi-rigid cable	6
Straight bulkhead jacks for flexible and semi-rigid cable	7
Right angle bulkhead jacks for flexible and semi-rigid cable	7

Receptacles

Straight and right angle bulkhead jack receptacles	8
Straight and right angle bulkhead plug receptacles	9
Straight P.C. board jacks	10
Straight bulkhead mounted P.C. board jacks	10
Straight P.C. board plugs	10
Right angle P.C. board jacks	11
Right angle bulkhead mounted P.C. board jacks	11
Right angle P.C. board plugs	11
Panel mounted jack receptacles	12
Stripline receptacles	13

Adapters

Straight adapters within series	14
Tee adapters within series	15

Resistive Terminations

Plug resistive terminations	16
Jack resistive terminations	16

Cable Assembly Instructions

Clamp type connectors for flexible cable	17
Crimp type connectors for flexible cable	18
Solder-clamp connectors for semi-rigid cable	19

Assembly Tooling	20
----------------------------	----

Mounting Dimensions	20
-------------------------------	----

Index by AEP Part Number	21
------------------------------------	----

About AEP	22
---------------------	----

Other AEP Product Lines	23
-----------------------------------	----



APPLIED ENGINEERING PRODUCTS

104 John W. Murphy Drive • P.O. Box 510 • New Haven, CT 06513

(203) 776-2813 • FAX (203) 776-8294

www.aepconnectors.com • e-mail: aepsales@aepconnectors.com

SMB Specifications

Specifications (MIL-PRF-39012 as applicable)

Materials:

Body components, male contacts: Brass per ASTM-B-16, alloy 360, 1/2 hard.

Female contacts: Beryllium copper per ASTM-B-196, Condition HT.

Insulators: Teflon TFE per ASTM-D-1710.

Finish:

Center contacts: Gold plated per current revision of MIL-PRF-39012*

Other metal parts: Gold or nickel plated to meet current MIL-PRF-39012 corrosion requirements.*

Electrical:

Impedance: 50Ω. **Frequency range:** DC–4 GHz. **Insulation Resistance:** 1,000 megohms minimum.

Voltage Rating: 250VRMS @ sea level (RG-178 cable); 335VRMS @ sea level (RG-316 cable).

Dielectric Withstanding Voltage: 750VRMS @ sea level (RG-178 cable); 1000VRMS @ sea level (RG-316 cable).

Contact Resistance:

Straight connectors: Initial: 6 milliohms maximum; after environmental test conditions: 8 milliohms maximum.

Right angle connectors: Initial: 12 milliohms maximum; after environmental test conditions: 16 milliohms maximum.

Corona level: 125V @70,000 ft. **RF highpot:** 400 VRMS @ 5 MHz.

RF leakage: -55 dB min @ 2–3 GHz. **Insertion loss:** .30 dB max (straight connectors), .60 dB max (right angle connectors) @ 1.5 GHz.

VSWR:	Cable	Straight connector	Right angle connector
	RG-178	$1.30 + (.04 \times F[\text{GHz}])$	$1.45 + (.06 \times F[\text{GHz}])$
	RG-316	$1.25 + (.04 \times F[\text{GHz}])$	$1.35 + (.04 \times F[\text{GHz}])$

Mechanical:

Force to engage: 14 pounds max.

Contact retention: 2 pounds min axial force. **Durability:** 500 mating cycles.

Environmental (MIL-STD-202):

Temperature range: -65° C to +165° C. **Corrosion:** Method 101, condition B, 5% salt solution.

Vibration (Method 204): Condition B.

Mechanical shock (Method 213): Condition B. **Thermal shock (Method 107):** Condition B.

*These specifications change periodically with updates to MIL-PRF-39012 requirements. Contact factory for latest specifications.

Interface Dimensions

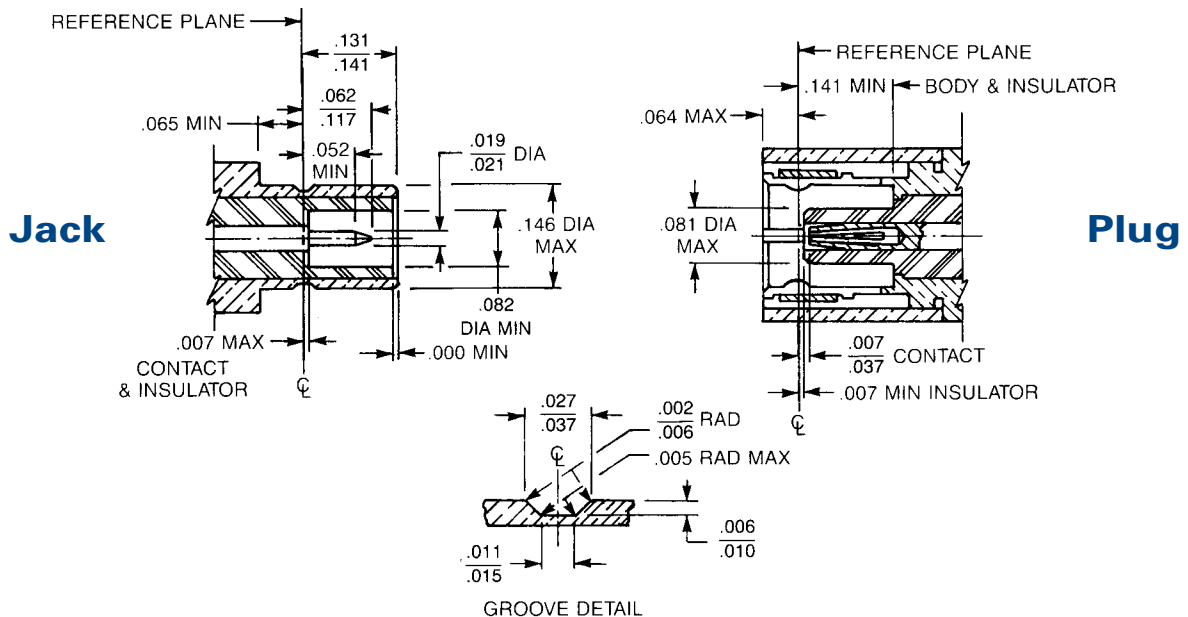

SMB Cable Attachment Methods

All SMB cable connectors in this catalog have captivated contacts which are soldered to the cable center conductor.

Both crimp and clamp types for flexible cable grip the cable braid with a force greater than the breaking strength of the braid.

Clamp Type For Flexible Cable

These connectors can be assembled without special tooling, and are field replaceable. They provide metal-to-metal clamping of the cable braid.

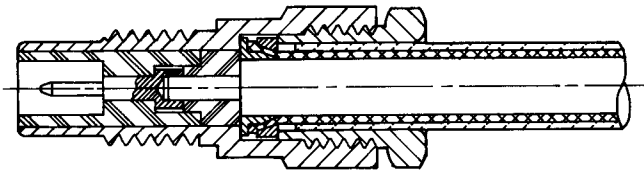

Crimp Type For Flexible Cable

Crimping the cable braid is the most reliable and repeatable method of cable assembly, and provides support for the cable during flexure. AEP crimp type connectors are assembled quickly and easily using readily-available commercial or MIL crimp tools.

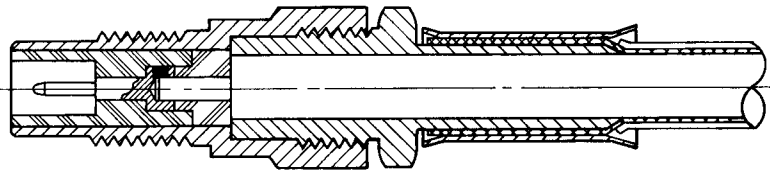

Solder-Clamp For Semi-Rigid Cable

This method allows retrimming of the cable dielectric, if necessary, during assembly. Connectors can be repositioned relative to the cable after assembly by loosening the clamp nut. Solder-clamp connectors are field replaceable without special tools.

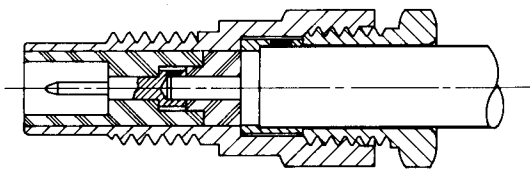

SMB Cable Plugs

Click on part number to go directly to cable assembly instructions

Straight Plugs

Straight Female Cable Plug

Clamp type for flexible cable: Solder-clamp for semi-rigid cable:
2002-1551-0XX (Gold plated) **2002-1541-0XX** (Gold plated)
2002-7551-0XX (Nickel plated) **2002-7541-0XX** (Nickel plated)

QPL version available (M39012/67)

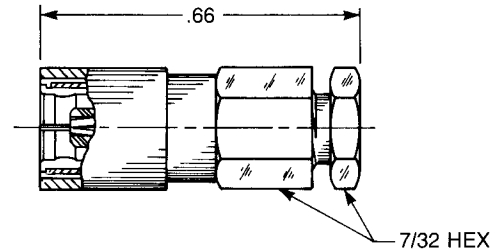

Straight Female Cable Plug

Crimp type for flexible cable:
2002-1571-0XX (Gold plated)
2002-7571-0XX (Nickel plated)

QPL version available (M39012/67)

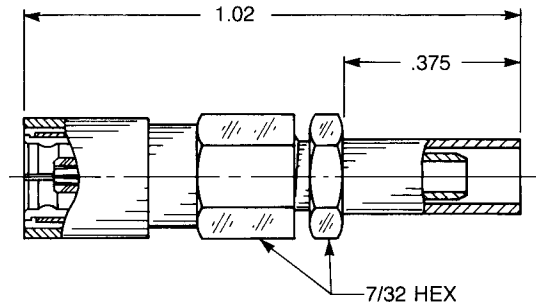

Right Angle Plugs

Right Angle Female Cable Plug

Clamp type for flexible cable:
2005-1551-0XX (Gold plated)
2005-7551-0XX (Nickel plated)

Solder-clamp for semi-rigid cable:
2005-1541-0XX (Gold plated)
2005-7541-0XX (Nickel plated)

QPL version available (M39012/69)

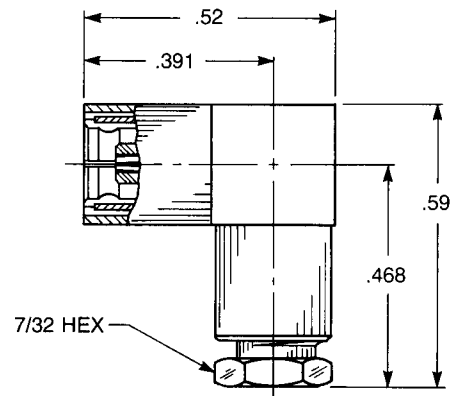

Right Angle Female Cable Plug

Crimp type for flexible cable:
2105-1521-0XX (Gold plated)
2105-7521-0XX (Nickel plated)

QPL version available (M39012/69)

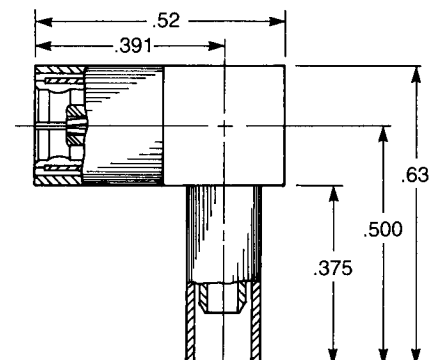

Substitute the appropriate cable group number for "XX" when ordering:

GROUP	CABLE TYPES	GROUP	CABLE TYPES	GROUP	CABLE TYPES
02	RG178, RG196, M17/93, M17/169	05	RG178DS, RG196DS	10	.085" semi-rigid, RG405, M17/133
03	RG174, RG179, RG316, M17/113, M17/119, M17/172, M17/189	09	.141" semi-rigid, RG 402M17/130	19	RG174DS, RG316DS, M17/151, M17/152, Times RD-316

SMB Cable Plugs

Click on part number to go directly to cable assembly instructions

Straight Bulkhead Mounted Plugs

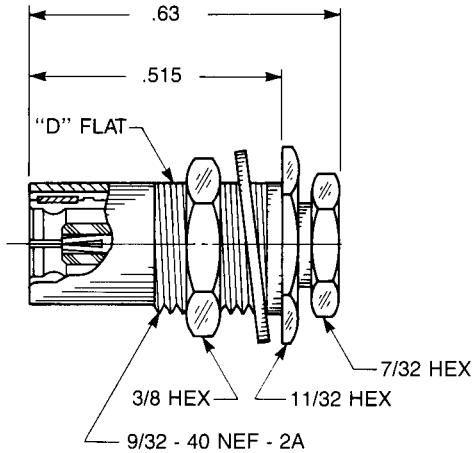

Bulkhead Mounted Straight Cable Plug

Clamp type for flexible cable:
2028-1551-0XX (Gold plated)
2028-7551-0XX (Nickel plated)

Solder-clamp for semi-rigid:
2028-1541-0XX (Gold plated)
2028-7541-0XX (Nickel plated)

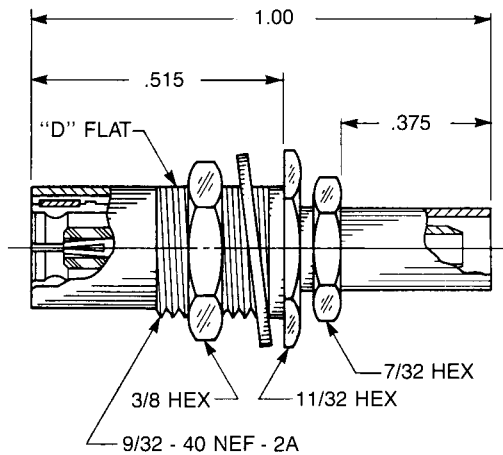

Bulkhead Mounted Straight Cable Plug

Crimp type for flexible cable:
2028-1571-0XX (Gold plated)
2028-7571-0XX (Nickel plated)

Substitute the appropriate cable group number for "XX" when ordering:

GROUP	CABLE TYPES	GROUP	CABLE TYPES	GROUP	CABLE TYPES
02	RG178, RG196, M17/93, M17/169	05	RG178DS, RG196DS	10	.085" semi-rigid, RG405, M17/133
03	RG174, RG179, RG316, M17/113, M17/119, M17/172, M17/189	09	.141" semi-rigid, RG 402M17/130	19	RG174DS, RG316DS, M17/151, M17/152, Times RD-316



APPLIED ENGINEERING PRODUCTS

(203) 776-2813 • FAX (203) 776-8294

www.aepconnectors.com • aepsales@aepconnectors.com

SMB Cable Jacks

Click on part number to go directly to cable assembly instructions

Straight Jacks

Straight Male Cable Jack

Clamp type for flexible cable: Solder-clamp for semi-rigid cable:
2001-1551-0XX (Gold plated) **2001-1541-0XX** (Gold plated)
2001-7551-0XX (Nickel plated) **2001-7541-0XX** (Nickel plated)
 QPL version available (M39012/68)

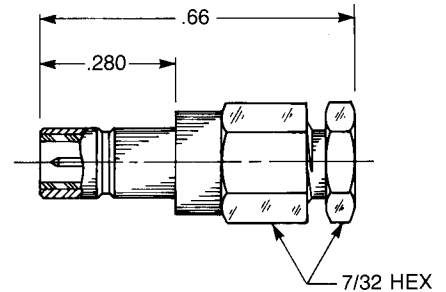

Straight Male Cable Jack

Crimp type for flexible cable:
2001-1571-0XX (Gold plated)
2001-7571-0XX (Nickel plated)
 QPL version available (M39012/68)

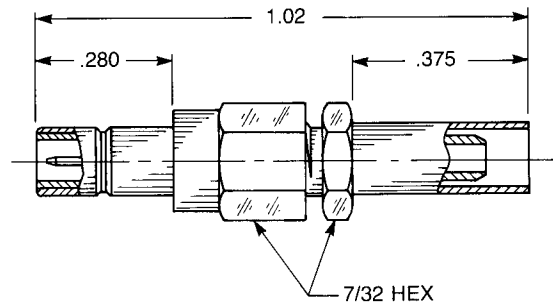

Right Angle Jacks

Right Angle Male Cable Jack

Clamp type for flexible cable:
2041-1551-0XX (Gold plated)
2041-7551-0XX (Nickel plated)
 Solder-clamp for semi-rigid cable:
2041-1541-0XX (Gold plated)
2041-7541-0XX (Nickel plated)

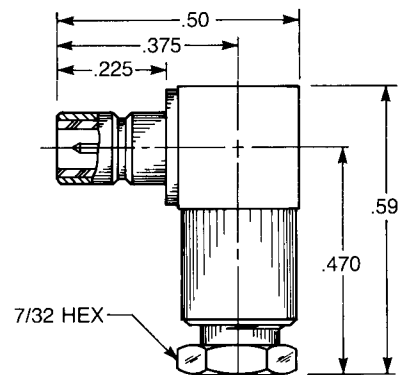

Right Angle Male Cable Jack

Crimp type for flexible cable:
2141-1521-0XX (Gold plated)
2141-7521-0XX (Nickel plated)

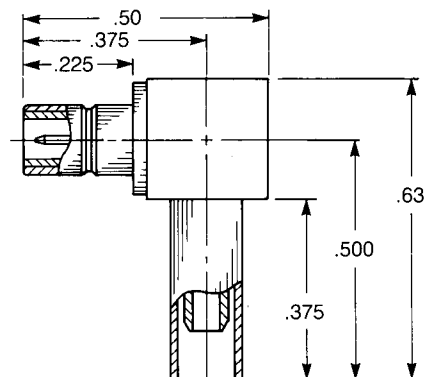

Substitute the appropriate cable group number for "XX" when ordering:

GROUP	CABLE TYPES	GROUP	CABLE TYPES	GROUP	CABLE TYPES
02	RG178, RG196, M17/93, M17/169	05	RG178DS, RG196DS	10	.085" semi-rigid, RG405, M17/133
03	RG174, RG179, RG316, M17/113, M17/119, M17/172, M17/189	09	.141" semi-rigid, RG 402M17/130	19	RG174DS, RG316DS, M17/151, M17/152, Times RD-316

SMB Bulkhead Mounted Cable Jacks

Click on part number to go directly to cable assembly instructions

Straight Jacks

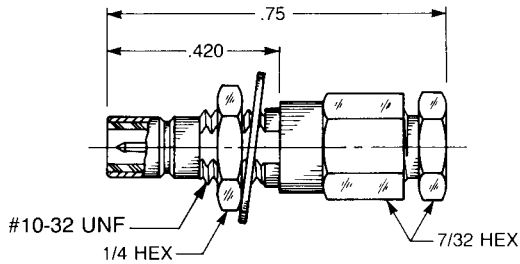

Straight Male Bulkhead Cable Jack

Clamp type for flexible cable: Solder-clamp for semi-rigid cable:
 2003-1551-0XX (Gold plated) 2003-1541-0XX (Gold plated)
 2003-7551-0XX (Nickel plated) 2003-7541-0XX (Nickel plated)
 QPL version available (M39012/70)

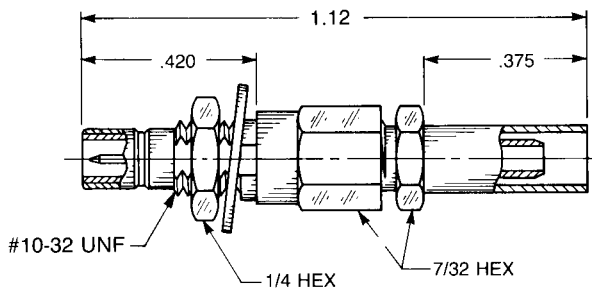

Straight Male Bulkhead Cable Jack

Crimp type for flexible cable:
 2003-1571-0XX (Gold plated)
 2003-7571-0XX (Nickel plated)

QPL version available (M39012/70)

Right Angle Jacks

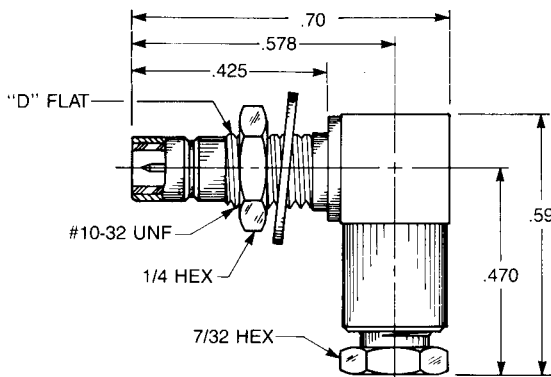

Bulkhead Mounted Right Angle Male Cable Jack

Clamp type for flexible cable:
 2006-1551-0XX (Gold plated)
 2006-7551-0XX (Nickel plated)

Solder-clamp for semi-rigid cable:
 2006-1541-0XX (Gold plated)
 2006-7541-0XX (Nickel plated)

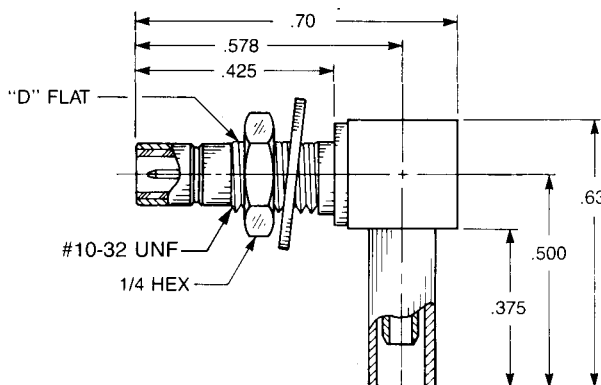

Bulkhead Mounted Right Angle Male Cable Jack

Crimp type for flexible cable:
 2106-1521-0XX (Gold plated)
 2106-7521-0XX (Nickel plated)

Substitute the appropriate cable group number for "XX" when ordering:

GROUP	CABLE TYPES	GROUP	CABLE TYPES	GROUP	CABLE TYPES
02	RG178, RG196, M17/93, M17/169	05	RG178DS, RG196DS	10	.085" semi-rigid, RG405, M17/133
03	RG174, RG179, RG316, M17/113, M17/119, M17/172, M17/189	09	.141" semi-rigid, RG 402M17/130	19	RG174DS, RG316DS, M17/151, M17/152, Times RD-316

SMB Bulkhead Jack Receptacles

Straight Jacks

Straight Male Bulkhead Jack Receptacle

- Solder pot contact
- Rear mount

2004-1511-000 (Gold plated)

2004-7511-000 (Nickel plated)

QPL version available (M39012/71)

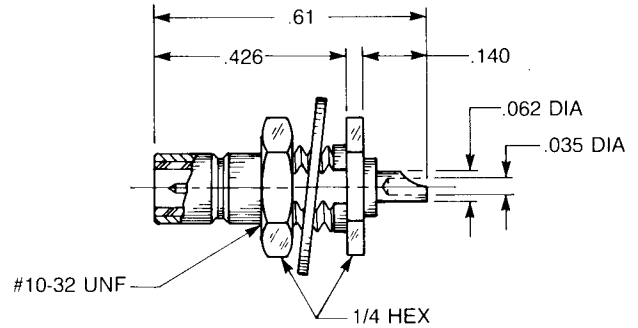

Straight Male Bulkhead Jack Receptacle

- Solder pot contact
- Front mount

2019-1511-000 (Gold plated)

2019-7511-000 (Nickel plated)

QPL version available (M39012/71)

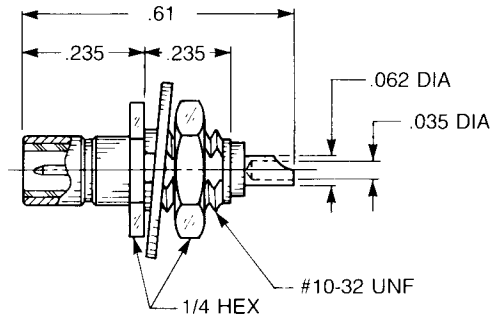

Straight Male Bulkhead Jack Receptacle

- Solder pot contact
- Recessed front mount

2014-1511-000 (Gold plated)

2014-7511-000 (Nickel plated)

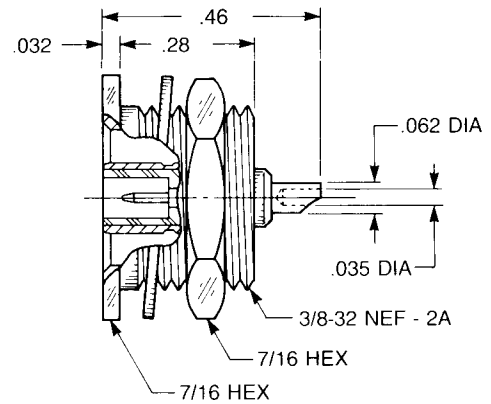

Right Angle Jacks

Right Angle Male Bulkhead Jack Receptacle

- Solder pot contact
- Front mount

2012-1511-000 (Gold plated)

2012-7511-000 (Nickel plated)

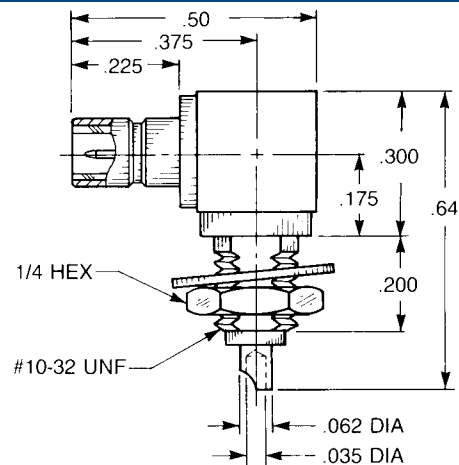

(All fit .093" max panel thickness)

SMB Bulkhead Plug Receptacles

Straight Plugs

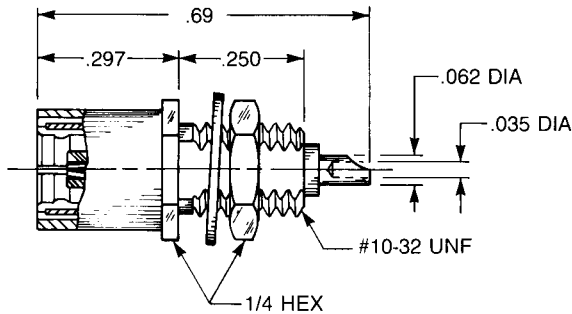

Straight Female Bulkhead Plug Receptacle

- Solder pot contact
- Front mount

2017-1511-000 (Gold plated)
2017-7511-000 (Nickel plated)

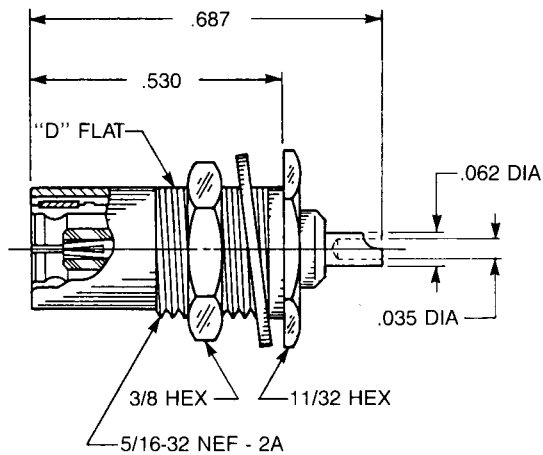

Straight Female Bulkhead Plug Receptacle

- Solder pot contact
- Rear mount

2048-1511-000 (Gold plated)
2048-7511-000 (Nickel plated)

Right Angle Plugs

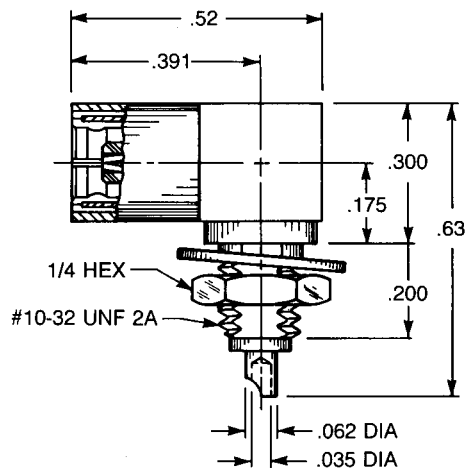

Right Angle Female Bulkhead Plug Receptacle

- Solder pot contact
- Front mount

2097-1511-000 (Gold plated)
2097-7511-000 (Nickel plated)

(All fit .093" max panel thickness)



APPLIED ENGINEERING PRODUCTS

(203) 776-2813 • FAX (203) 776-8294

www.aepconnectors.com • aepsales@aepconnectors.com

SMB P.C. Board Receptacles

Straight Jacks

Straight Male Jack Receptacle

2009-1511-000 (Gold plated)
2009-7511-000 (Nickel plated)

QPL version available
(M39012/95)

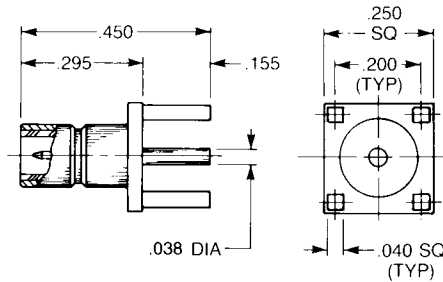

2009-1511-050 (Gold plated)
2009-7511-050 (Nickel plated)

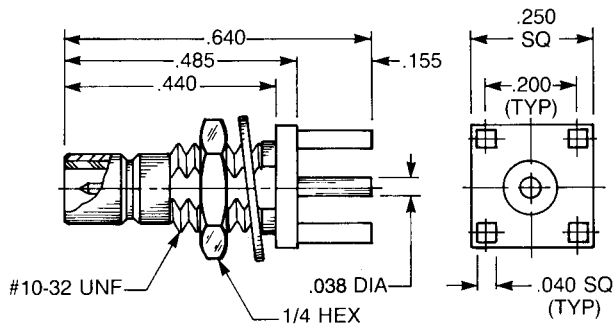
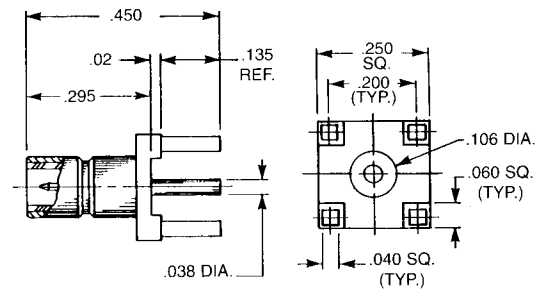

Bulkhead Mounted Straight Male Jack P.C. Board Receptacle

2109-1511-000 (Gold plated)
2109-7511-000 (Nickel plated)

Straight Plug

Straight Female Plug Receptacle

2025-1511-000 (Gold plated)
2025-7511-000 (Nickel plated)

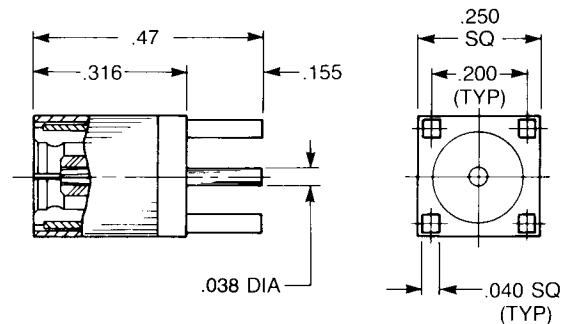

SMB P.C. Board Receptacles

Right Angle Jacks

Right Angle Male Jack Receptacle

A	B	C	D
.43	.15	.50	.38
2010-1511-000 (Gold plated)			
2010-7511-000 (Nickel plated)			

A	B	C	D
.50	.215	.56	.437
2010-1511-002 (Gold plated)			
2010-7511-002 (Nickel plated)			

QPL version available (M39012/96)

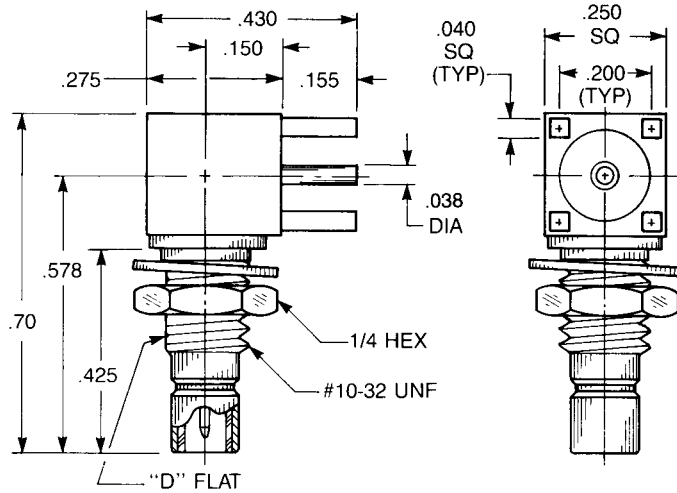
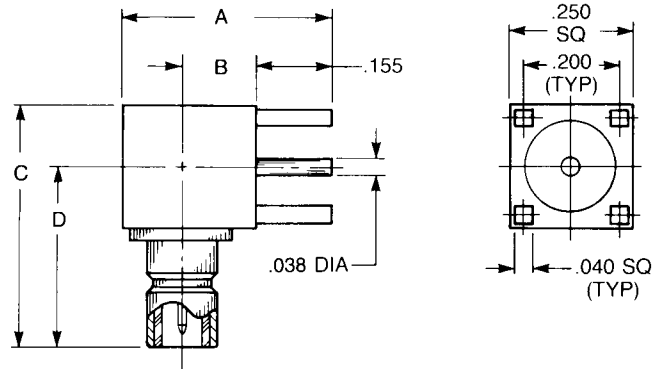

Bulkhead Mounted Right Angle Male Jack P.C. Board Receptacle

2110-1511-000 (Gold plated)
2110-7511-000 (Nickel plated)

Right Angle Plug

Right Angle Female Plug Receptacle

2042-1511-000 (Gold plated)
2042-7511-000 (Nickel plated)

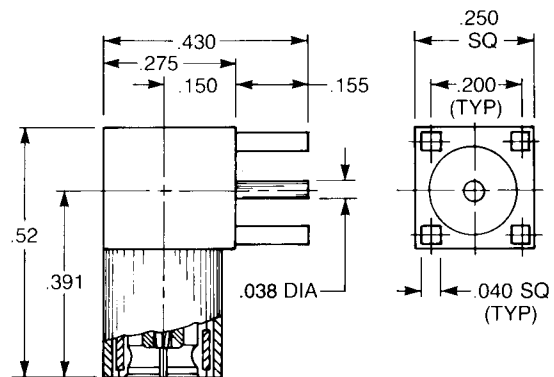

SMB Panel Receptacles

Straight Jack

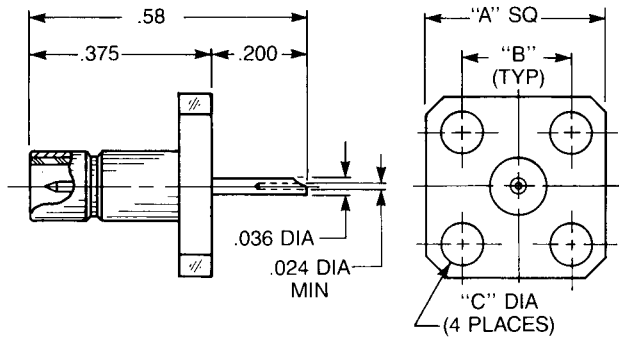

Straight Male Panel Receptacle

A sq.	B	C dia.
.500	.340	.102
2486-1511-000		(Gold plated)
2486-7511-000		(Nickel plated)

A sq.	B	C dia.
.375	.232	.093
2484-1511-000		(Gold plated)
2484-7511-000		(Nickel plated)

Right Angle Jack

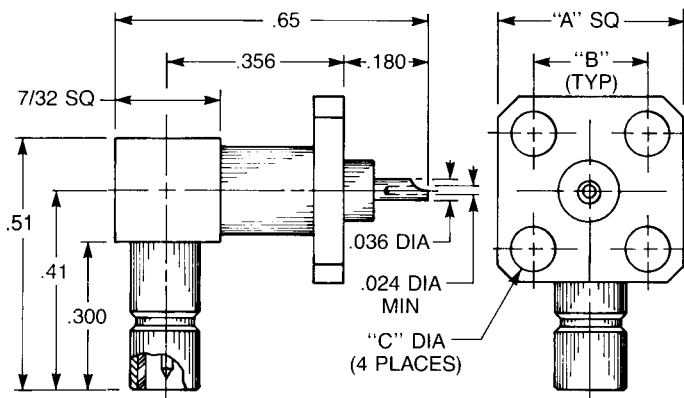

Right Angle Male Panel Receptacle

A sq.	B	C dia.
.500	.340	.102
2490-1511-000		(Gold plated)
2490-7511-000		(Nickel plated)

A sq.	B	C dia.
.375	.232	.093
2488-1511-000		(Gold plated)
2488-7511-000		(Nickel plated)

SMB Stripline Receptacles

Straight Jack

Straight Male Top Launch Jack

- Non-captive contact

Dim. A Part number:

.031	2029-1211-001	(Gold plated)
	2029-7211-001	(Nickel plated)
.063	2029-1211-002	(Gold plated)
	2029-7211-002	(Nickel plated)
.125	2029-1211-003	(Gold plated)
	2029-7211-003	(Nickel plated)

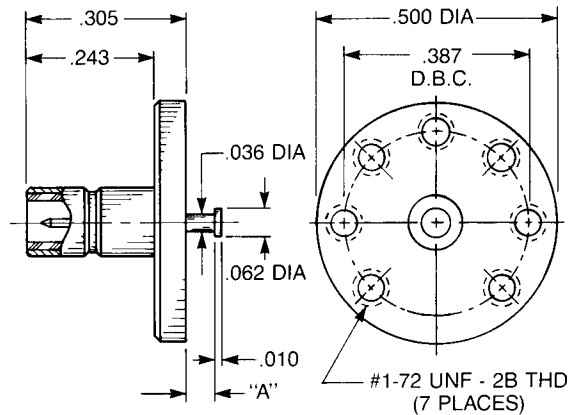

Right Angle Jack

Right Angle Male Top Launch Jack

- Removable rear contact

Dim. A Part number:

.031	2092-1511-001	(Gold plated)
	2092-7511-001	(Nickel plated)
.063	2092-1511-002	(Gold plated)
	2092-7511-002	(Nickel plated)
.125	2092-1511-003	(Gold plated)
	2092-7511-003	(Nickel plated)

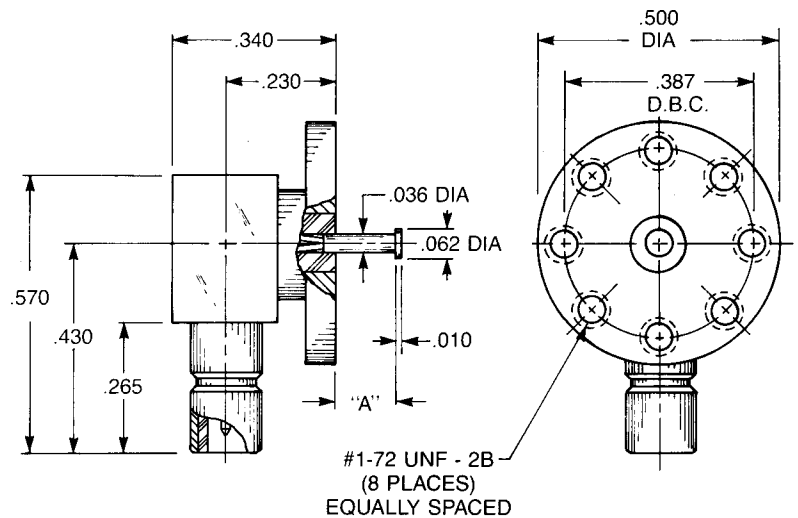

SMB Adapters

Straight Adapters

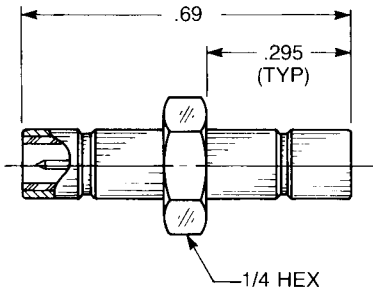

Straight Male Jack To Jack Adapter

- Connects two plugs

5213-1501-000 (Gold plated)
5213-7501-000 (Nickel plated)

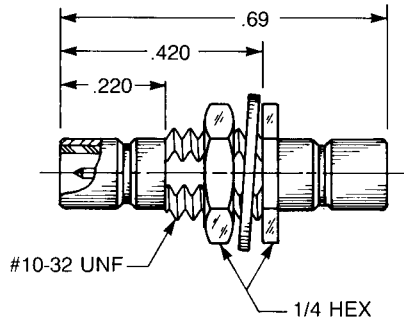

Bulkhead Mounted Straight Male Jack To Jack Adapter

- Connects two plugs
- For .093" max. panel

5222-1501-000 (Gold plated)
5222-7501-000 (Nickel plated)

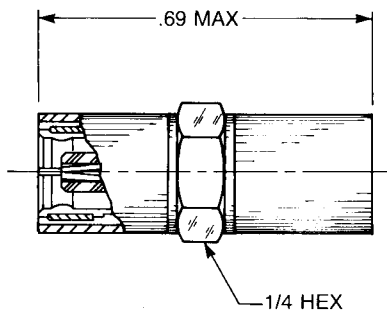

Straight Female Plug To Plug Adapter

- Connects two jacks

5216-1501-000 (Gold plated)
5216-7501-000 (Nickel plated)



SMB Adapters

Tee Adapters

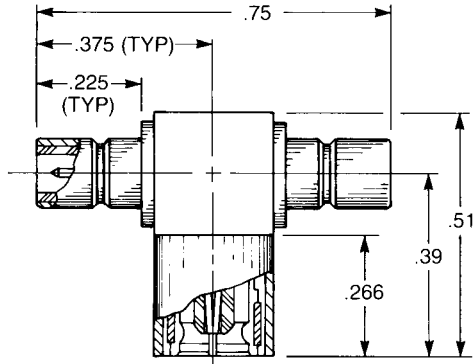

Tee Adapter (Unmatched Power Divider) Jack To Plug To Jack

- Connects two plugs and one jack

5215-1501-000 (Gold plated)

5215-7501-000 (Nickel plated)

Tee Adapter (Unmatched Power Divider) Jack To Jack To Jack

- Connects three plugs

5207-1501-000 (Gold plated)

5207-7501-000 (Nickel plated)

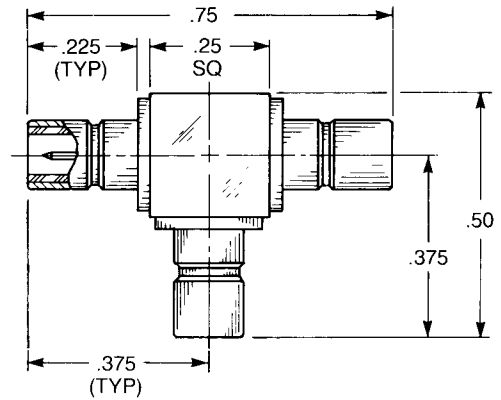

Tee Adapter (Unmatched Power Divider) Plug To Plug To Plug

- Connects three jacks

5208-1501-000 (Gold plated)

5208-7501-000 (Nickel plated)

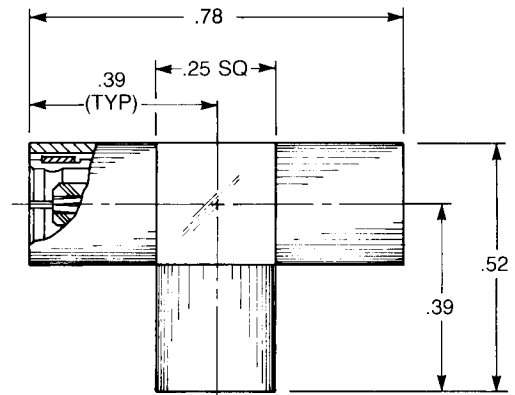

SMB Terminations

Plug Termination

Female Plug Resistive Termination

(Dummy load)

Standard resistor:
51 ohm, 1/2 watt,
5% tolerance

2036-1511-051 (Gold plated)

2036-7511-051 (Nickel plated)

Available with other resistances.

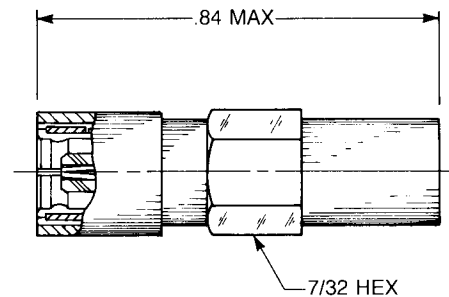

Jack Termination

Male Jack Resistive Termination

(Dummy load)

Standard resistor:
51 ohm, 1/2 watt,
5% tolerance

2037-1511-051 (Gold plated)

2037-7511-051 (Nickel plated)

Available with other resistances

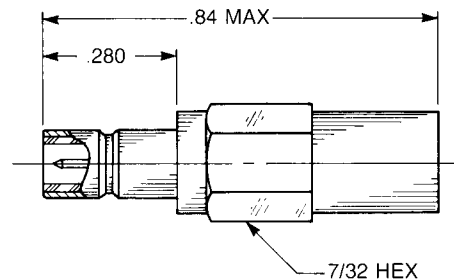

Cable Assembly Instructions

Clamp type connectors for flexible cable

Straight Connectors—Flexible Cable

Parts list

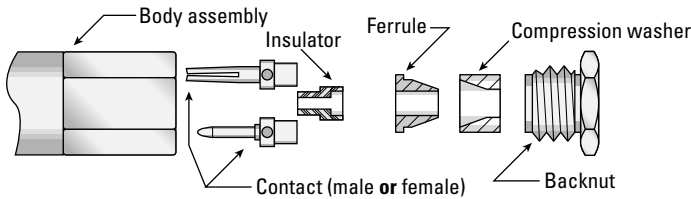

1

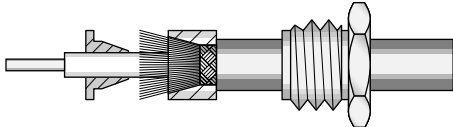

- Trim cable per trim code below; tin end of center conductor.
- Slide backnut onto cable. Slide compression washer onto cable in the orientation shown until it stops against cable jacket.
- Flare cable braid by rotating dielectric and slide ferrule under braid.

2

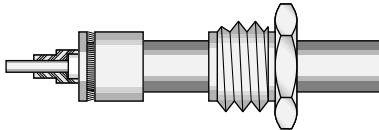

- Press ferrule against compression washer.
- Trim excess braid flush with outer diameter of compression washer and ferrule.
- Assemble insulator over cable center conductor and dielectric.

3

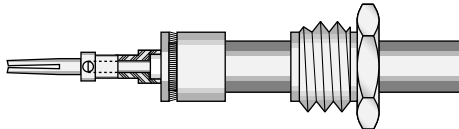

- Assemble contact onto cable center conductor.
- Solder contact to center conductor by heating rear of contact (do not feed additional solder through inspection hole in contact).

4

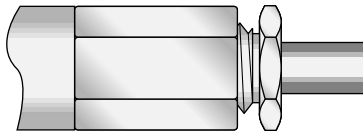

- Insert cable assembly into body assembly. Tighten to 90–100 inch-ounces torque. (Hold cable/hardware assembly stationary and rotate body when tightening.)

Cable Trim Dimensions

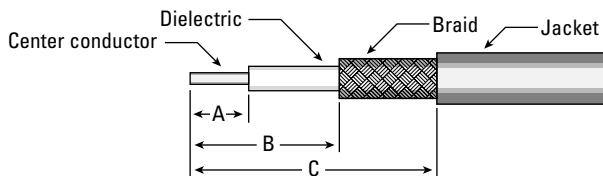

CONNECTOR TYPE	A	B	C
STRAIGHT CONNECTORS	.080	.120	.240
RIGHT ANGLE CONNECTORS	.080	.180	.300

Right Angle Connectors—Flexible Cable

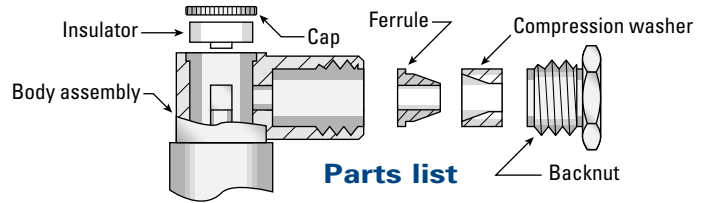

1

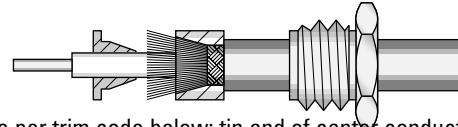

- Trim cable per trim code below; tin end of center conductor.
- Slide backnut onto cable. Slide compression washer onto cable in the orientation shown until it stops against cable jacket.
- Flare cable braid by rotating dielectric and slide ferrule under braid.

2

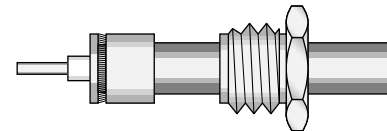

- Press ferrule against compression washer.
- Trim excess braid flush with outer diameter of compression washer and ferrule.
- Assemble insulator over cable center conductor and dielectric.

3

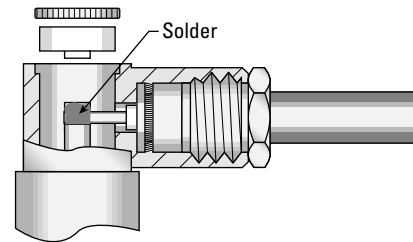

- Insert cable assembly into body assembly. Tighten to 90–100 inch-ounces torque. (Hold cable/hardware assembly stationary and rotate body when tightening.)
- Solder center conductor into notch in rear of contact with .025–.032" diameter chisel-tip soldering iron.
- Solder should cover center conductor, but not extend over top of notch in contact, or exceed contact diameter.

4

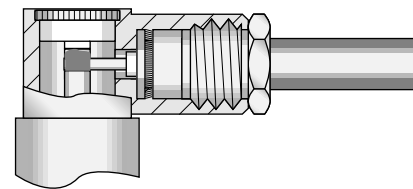

- Place insulator in body cavity, and press cap into place. Properly assembled cap will be slightly below end of body assembly.

Cable Assembly Instructions

Crimp type connectors for flexible cable

Straight Connectors—Flexible Cable

Parts list

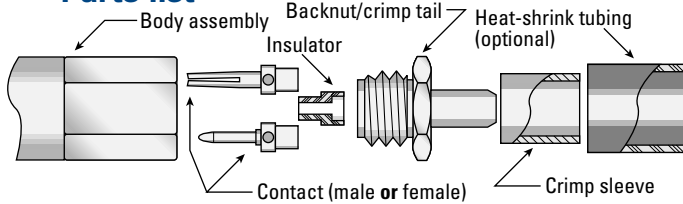

1

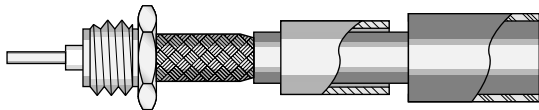

- Trim cable per trim code below; tin end of center conductor.
- Slide heat-shrink tubing and crimp sleeve over cable.
- Flare cable braid by rotating dielectric and slide cable into crimp tail.

2

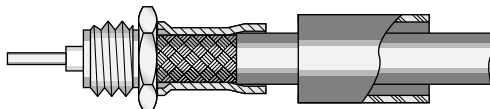

- Position cable so braid touches rear of back nut.
- Slide crimp sleeve forward to touch rear of back nut.
- Crimp braid with appropriate die size from chart below.

3

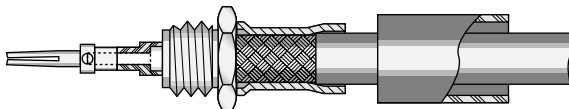

- Assemble insulator and contact onto cable dielectric and center conductor.
- Solder contact to center conductor by heating rear of contact (do not feed additional solder through inspection hole in contact).

4

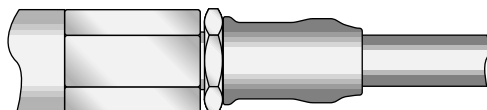

- Insert cable assembly into body assembly. Tighten to 90–100 inch-ounces torque. (Hold cable/hardware assembly stationary and rotate body when tightening.)
- Slide shrink tubing over crimp sleeve and shrink to fit.

Cable Trim Dimensions

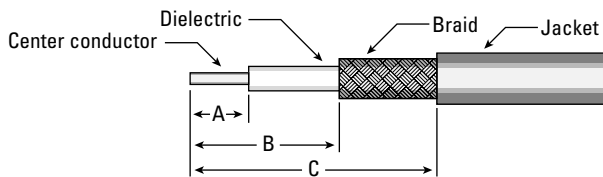

CONNECTOR TYPE	A	B	C
STRAIGHT CONNECTORS	.100	.430	.700
RIGHT ANGLE CONNECTORS	.070	.200	.450

Right Angle Connectors—Flexible Cable

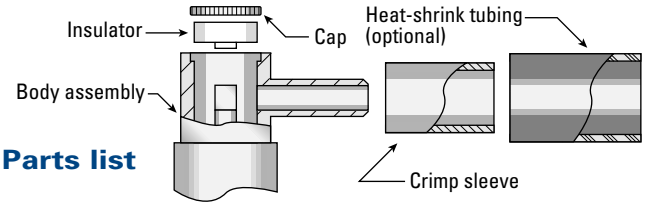

1

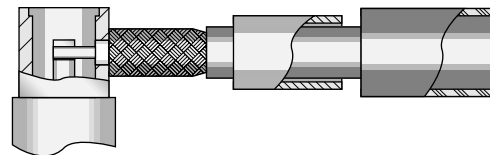

- Trim cable per trim code below; tin end of center conductor.
- Slide heat-shrink tubing and crimp sleeve over cable.
- Flare cable braid by rotating dielectric and slide cable into crimp tail.

2

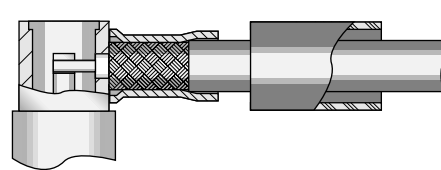

- Position cable so braid touches rear of body assembly.
- Slide crimp sleeve forward to touch rear of body assembly.
- Crimp braid with appropriate die size from chart below.

3

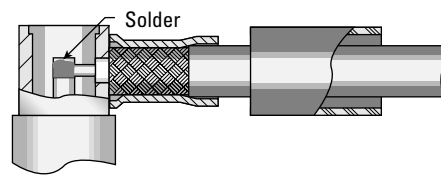

- Solder center conductor into notch in rear of contact with .025–.032" diameter chisel-tip soldering iron.
- Solder should cover center conductor, but not extend over top of notch in contact, or exceed contact diameter.

4

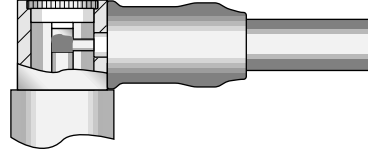

- Place insulator in body cavity, and press cap into place. Properly assembled cap will be slightly below end of body assembly.
- Slide shrink tubing over crimp sleeve and shrink to fit.

Crimp Die Sizes

CABLE GROUP	HEX DIE SIZE
02	.105
03	.128
05	.128
19	.128



Cable Assembly Instructions

Solder-clamp connectors for semi-rigid cable

Straight Connectors—Semi-Rigid Cable

Parts list

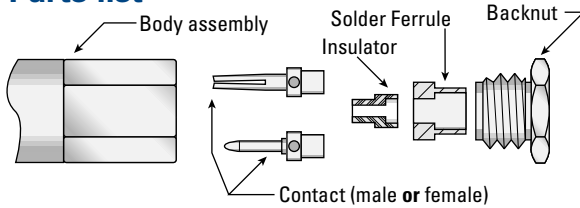

1

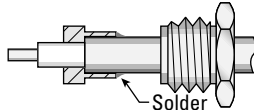

- Trim cable per trim code below; tin end of center conductor.
- Slide backnut over cable. Slide solder ferrule over cable until it stops against cable jacket.
- Solder cable jacket to ferrule.

2

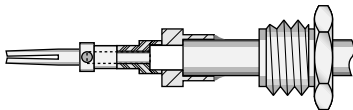

- Assemble insulator and contact onto cable dielectric and center conductor. If insulator is not flush against solder ferrule due to dielectric extrusion, retrim dielectric.
- Solder contact to center conductor by heating rear of contact (do not feed additional solder through inspection hole in contact).

3

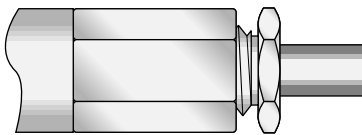

- Insert cable assembly into body assembly. Tighten to 90–100 inch-ounces torque. (Hold cable/hardware assembly stationary and rotate body when tightening.)

Right Angle Connectors—Semi-Rigid Cable

Parts list

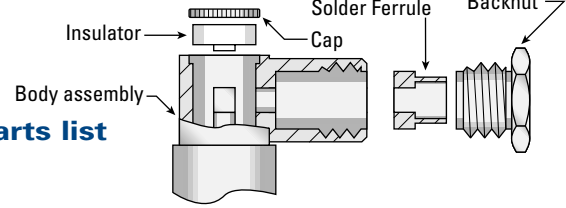

1

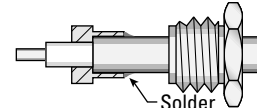

- Trim cable per trim code below; tin end of center conductor.
- Slide backnut over cable. Slide solder ferrule over cable until it stops against cable jacket.
- Solder cable jacket to ferrule.

2

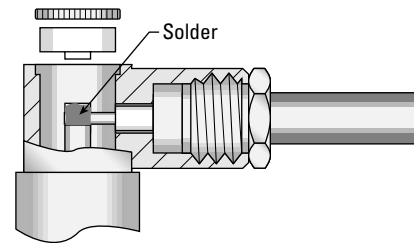

- Insert cable assembly into body assembly. Tighten to 90–100 inch-ounces torque. (Hold cable/hardware assembly stationary and rotate body when tightening.)
- Solder center conductor into notch in rear of contact with .025–.032" diameter chisel-tip soldering iron.
- Solder should cover center conductor, but not extend over top of notch in contact, or exceed contact diameter.

3

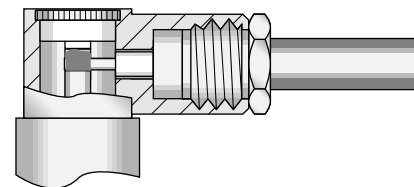

- Place insulator in body cavity, and press cap into place. Properly assembled cap will be slightly below end of body assembly.

Cable Trim Dimensions

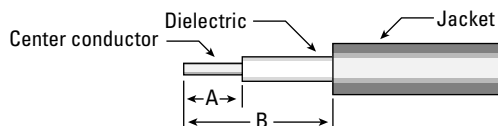

CONNECTOR TYPE	A	B
STRAIGHT CONNECTORS— .085" cable	.090	.170
STRAIGHT CONNECTORS— .141" cable	.105	.130
RIGHT ANGLE CONNECTORS	.110	.150



Mounting Dimensions

Bulkhead Receptacles

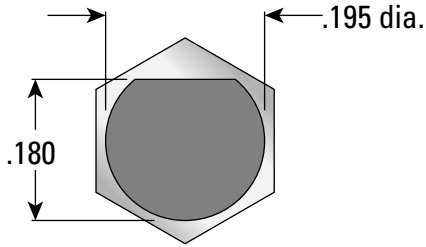

Flat of mounting surface is aligned with body hex as shown.

P.C. Board Receptacles

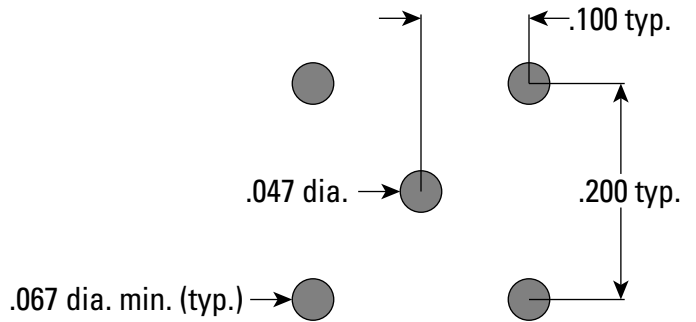

Assembly Tooling

Crimp tool

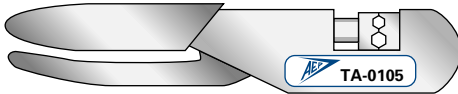

DESCRIPTION	AEP P/N
Crimp tool with .105" and .128" hex dies	TA-0105

Torque Wrench

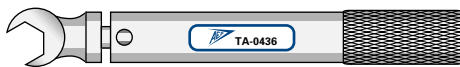

DESCRIPTION	AEP P/N
Torque wrench with 7/32" jaws for SMB connector backnuts; 95 inch-ounces torque	TA-0436

Capping Press

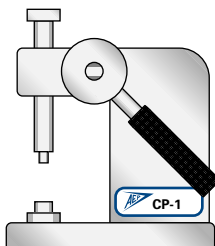

DESCRIPTION	AEP P/N
Capping tool (arbor press) with base for SMB right angle plugs	CP-1
Capping tool (arbor press) with base for SMB right angle jacks	CP-6

Index by Part Number

Click on any line below to go directly to the appropriate page

P/N	Page	P/N	Page
2001-1541-0XX*	6	2029-7211-002	13
2001-1551-0XX*	6	2029-7211-003	13
2001-1571-0XX*	6	2036-1511-051	16
2001-7541-0XX*	6	2036-7511-051	16
2001-7551-0XX*	6	2037-1511-051	16
2001-7571-0XX*	6	2037-7511-051	16
2002-1541-0XX*	4	2041-1541-0XX*	6
2002-1551-0XX*	4	2041-1551-0XX*	6
2002-1571-0XX*	4	2041-7541-0XX*	6
2002-7541-0XX*	4	2041-7551-0XX*	6
2002-7551-0XX*	4	2042-1511-000	11
2002-7571-0XX*	4	2042-7511-000	11
2003-1541-0XX*	7	2048-1511-000	9
2003-1551-0XX*	7	2048-7511-000	9
2003-1571-0XX*	7	2092-1511-001	13
2003-7541-0XX*	7	2092-1511-002	13
2003-7551-0XX*	7	2092-1511-003	13
2003-7571-0XX*	7	2092-7511-001	13
2004-1511-000	8	2092-7511-002	13
2004-7511-000	8	2092-7511-003	13
2005-1541-0XX*	4	2097-1511-000	9
2005-1551-0XX*	4	2097-7511-000	9
2005-7541-0XX*	4	2105-1521-0XX*	4
2005-7551-0XX*	4	2105-7521-0XX*	4
2006-1541-0XX*	7	2106-1521-0XX*	7
2006-1551-0XX*	7	2106-7521-0XX*	7
2006-7541-0XX*	7	2109-1511-000	10
2006-7551-0XX*	7	2109-7511-000	10
2009-1511-000	10	2110-1511-000	11
2009-1511-050	10	2110-7511-000	11
2009-7511-000	10	2141-1521-0XX*	6
2009-7511-050	10	2141-7521-0XX*	6
2010-1511-000	11	2484-1511-000	12
2010-1511-002	11	2484-7511-000	12
2010-7511-000	11	2486-1511-000	12
2010-7511-002	11	2486-7511-000	12
2012-1511-000	8	2488-1511-000	12
2012-7511-000	8	2488-7511-000	12
2014-1511-000	8	2490-1511-000	12
2014-7511-000	8	2490-7511-000	12
2017-1511-000	9	5207-1501-000	15
2017-7511-000	9	5207-7501-000	15
2019-1511-000	8	5208-1501-000	15
2019-7511-000	8	5208-7501-000	15
2025-1511-000	10	5213-1501-000	14
2025-7511-000	10	5213-7501-000	14
2028-1541-0XX*	5	5215-1501-000	15
2028-1551-0XX*	5	5215-7501-000	15
2028-1571-0XX*	5	5216-1501-000	14
2028-7541-0XX*	5	5216-7501-000	14
2028-7551-0XX*	5	5222-1501-000	14
2028-7571-0XX*	5	5222-7501-000	14
2029-1211-001	13	CP-1	20
2029-1211-002	13	TA-0105	20
2029-1211-003	13	TA-0436	20
2029-7211-001	13		

* Indicates cable connectors with various types on specified page.



About Applied Engineering Products

Since our foundation in 1973, we have always believed that having our customers take a look "inside AEP" is important in fostering strong vendor/customer relationships. We are proud of our physical plant and equipment, but even more so of our dedicated staff. When customers see first-hand how AEP's people keep a constant focus on maintaining and improving

customer service and satisfaction, the reason for our consistently strong on-time delivery and quality records becomes clear.

We invite you to see for yourself. Call us to arrange a plant tour—or, if you can't make a visit, ask for your copy of *INSIDE AEP*, our facilities and capabilities brochure.

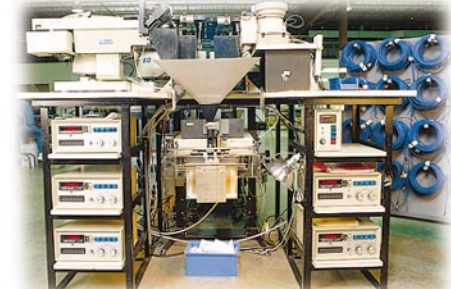

APPLIED ENGINEERING PRODUCTS

(203) 776-2813 • FAX (203) 776-8294

www.aepconnectors.com • aepsales@aepconnectors.com

The **SMB** connectors in this brochure are only part of our complete line of subminiature coaxial connectors and cable assemblies, including:

- **SMA**
- **SMB**
- **SMC**
- **SSMB**
- **SSMC**
- **SLB (Slide-on version of SMB)**
- **SSLB (Slide-on version of SSMB)**
- **75Ω Snap-on mating**
- **75Ω Screw-on mating**
- **Adapters within and between series**
- **Flexible cable assemblies**
- **Semi-rigid cable assemblies**
- **And over 100 styles of MIL-PRF-39012 QPL connectors in series SMA, SMB, and SMC**

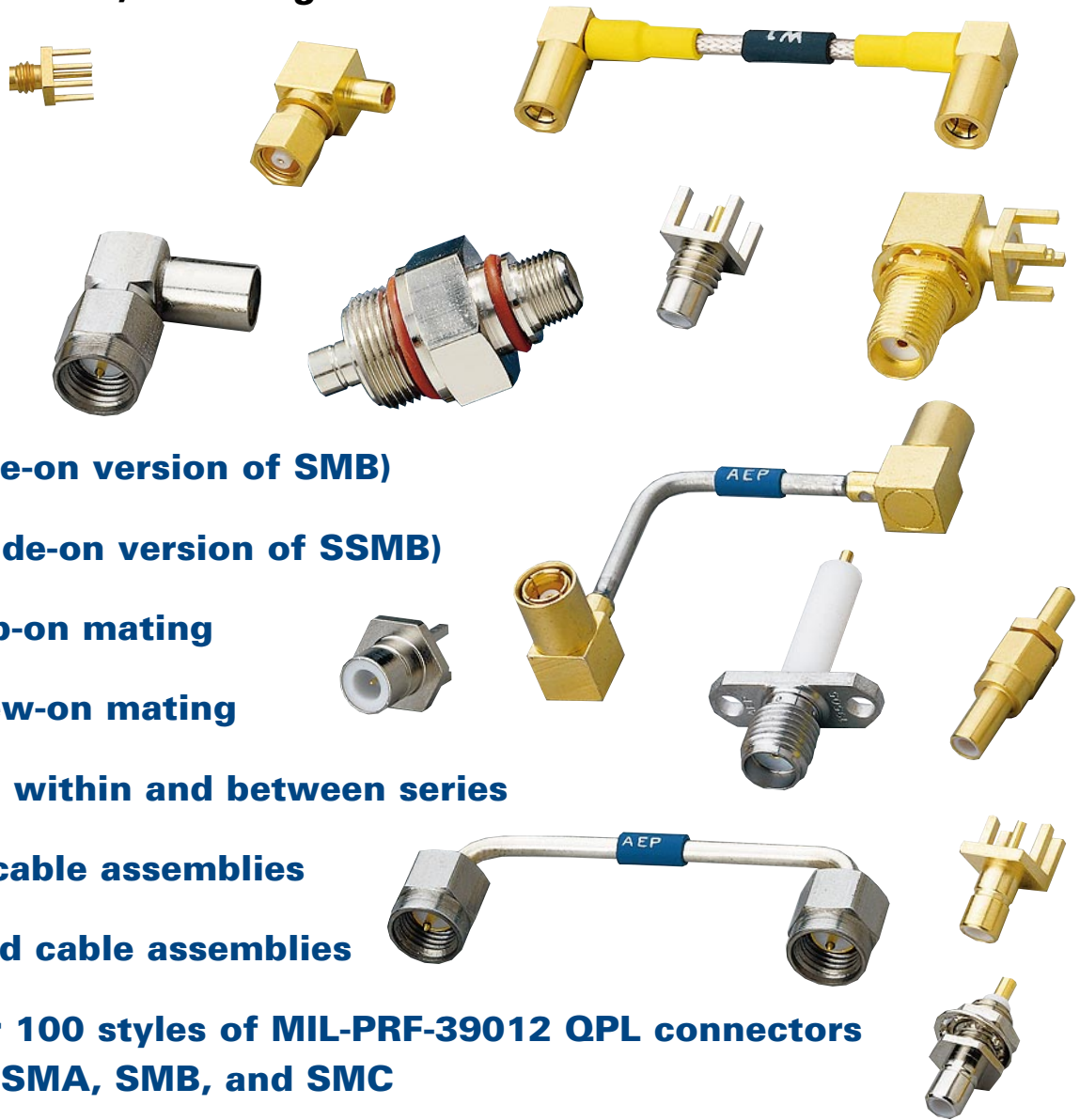

Call for your copy of our 184-page full catalog to see them all.



ISO 9001
CERTIFIED



APPLIED ENGINEERING PRODUCTS

104 John W. Murphy Drive • P.O. Box 510 • New Haven, CT 06513

(203) 776-2813 • FAX (203) 776-8294

www.aepconnectors.com • e-mail: aepsales@aepconnectors.com