



Space



Australian Representatives

ROJONE, PTY LTD.

Tel: 02 9829 1555

E: [sales@rojone.com.au](mailto:sales@rojone.com.au)

[www.rojone.com.au](http://www.rojone.com.au)

**Contents**

General Information ..... 7-2

Radiall Specifications ..... 7-3

Flight Models

Low power models ..... 7-6 to 7-11

High power models ..... 7-12 to 7-17

Thermal Vacuum for Ground Segments ..... 7-18 to 7-20

SECTION 7 TABLE OF CONTENTS

**General Information/Specifications**

**GENERAL INFORMATION/SPECIFICATIONS**

Radiall Hi-Rel switches are manufactured based on over 40 years of experience and thousands of products that have been designed, qualified, and delivered for both commercial and military applications. With a space heritage of over 25 years and products in flight on over 250 satellites around the world, Radiall guarantees the highest level of manufacturing, quality and reliability.

Radiall Hi-Rel coaxial switches have been fully evaluated and approved by the European Space Agency for Space use according to the generic specification ESCC3603. Radiall offers products tested at several levels based on the same hardware including:

- EM: Engineering Model
- QM: Qualification Model
- PFM: Proto Flight Model

Radiall also provides a full range of low cost Hi-Rel switches for space applications. These products, meet the requirements for communication satellite applications according to RAD-GEN-SWIT-001 and follow detailed specifications according to the Radiall part number list (see page 6-3).

**ENVIRONMENTAL CHARACTERISTICS**

		Qualification level
Operation temperature range		- 30°C / + 85°C
Non operation temperature range		- 40°C / + 85°C
Vibration	Sinus	5 – 100 Hz / 20g
	Random	20 – 2000 Hz / 28.57 grms
Schocks		½ sinus / 1200g / 0.25 ms
Pressure		Free space vacuum



## Radiall Specifications

### RADIALL BEST RUNNERS PART LIST (FM P/N):

Detail specification	Product	Power cap.	Connectors	Radiall P/N FM	Designation
RAD - DET - SPDT - 001	SPDT	Low power	SMA	R571 492 601	Fixing plate with pins
				R571 472 601	Lay Down with pins
				R571 471 601	Lay Down with D-sub
			SMA 2.9	R571 892 601	Fixing plate with pins
				R571 872 601	Lay Down with pins
				R571 871 601	Lay Down with D-sub
RAD - DET - SPDT - 002	SPDT	High power	TNC	R565 271 601	Lay Down with D-sub, High Cavity
				R565 371 601	Lay Down with D-sub, Standard Cavity
RAD - DET - DPDT - 006	DPDT	Low power	SMA	R578 483 601	Stand Up with D-sub
				R578 472 601	Lay Down with D-sub
				R578 482 601	Stand Up with pins
			SMA 2.9	R578 872 601	Lay Down with pins
				R578 883 601	Stand Up with D-sub
				R578 882 601	Stand Up with pins
RAD - DET - TSSD - 002	T-Switch Sequentiel	Low power	SMA	R587 432 601	Lay Down with pins
				R587 443 601	Stand up with D-sub
				R587 442 601	Stand up with pins
			SMA 2.9	R587 832 621	Lay Down with pins
				R587 842 621	Stand up with pins
				R587 843 621	Stand up with D-sub
RAD - DET - TRSD - 002	T-Switch	High power	TNC	R588 371 601	Lay Down with D-sub
				R588 381 611	Stand up with D-sub
RAD - DET - TRSD - 003	T-Switch Random	Low power	SMA	R587 492 601	Fixing plate with pins
				R587 472 601	Lay Down with pins
				R587 482 601	Stand up with pins
			SMA 2.9	R587 872 601	Lay Down with pins
				R587 882 601	Stand up with pins
				R587 883 601	Stand up with D-sub
RAD - DET - DP3T - 001	DP3T	Low power	SMA	R586 471 601	Lay Down with D-sub
			SMA 2.9	R586 871 601	Lay Down with D-sub
RAD - DET - DP3T - 002	DP3T	High power	TNC	R564 271 601	Lay Down with D-sub, High Cavity
				R564 371 601	Lay Down with D-sub, Standard Cavity
				R564 372 601	Lay Down with pins, Standard Cavity

## Low Power Coaxial SPDT Switch



### LOW-POWER LATCHING COAXIAL SPDT SWITCH according to Radiall specification

#### RAD-DET-SPDT-001

- DC to 22 GHz with SMA connectors
- Up to 31 GHz with SMA 2.9 connectors
- Telemetry circuit
- Suppression diodes
- D-Sub or solder pins
- Lay Down or Fixing plate
- 44 grams and up

## GENERAL SPECIFICATIONS

	Unit	Min	Typical	Max
Actuation Voltage	V	+22	+26	+29
Pick-Up Voltage	V			+20.5
Actuation Current	mA		129	139
@+29V, +25°C			164	176
@+29V, -30°C			105	113
@+29V, +85°C				
Switching Time	ms			20
Pulse Duration	ms	20		1000
Coil Resistance (at +25°C)	Ω	210	225	
RF Contact Resistance	mΩ			100
	mΩ		1000	
	mΩ	10		
	mA		100	
Coil Isolation at 500 VDC	MΩ	10		
Dielectric Withstanding at 50 or 60Hz	Vrms	500		
Mass	grams			44
Variant 001: SPDT, Fixing Plate, Pins				62
Variant 002: SPDT, Lay Down, Pins				72
Variant 003: SPDT, Lay Down, D-Sub				

## RF PERFORMANCES

### DC to 22 GHz SMA

Frequency	GHz	DC - 4.2	4.2 - 10.7	10.7 - 12.75	12.75 - 14.5	14.5 - 22
Insertion Loss (max)	dB	0.12	0.20	0.25	0.30	0.35
VSWR (max)	(dB)	1.20:1	1.20:1	1.20:1	1.25:1	1.33:1
Return Loss (min)		(21)	(21)	(21)	(19)	(17)
Isolation (min)	dB	70			65	60
E-Field Shielding Effectiveness (min)	dB	75	70	70	70	70

### Ka – band SMA 2.9

Frequency	GHz	17.5-21.5	21.5 - 27.5	27.5 - 31
Insertion Loss (max)	dB	0.45	0.45	0.50
VSWR (max)	(dB)	1.33:1	1.35:1	1.40:1
Return Loss (min)		(17.0)	(16.5)	(15.6)
Isolation (min)	dB	65	60	60
E-Field Shielding Effectiveness (min)	dB	70	60	60
Power Handling (max)	W	10	5	

## Low Power Coaxial SPDT Switch

### SCHEMATICS & DRAWINGS

SDPT, lay down, pins:

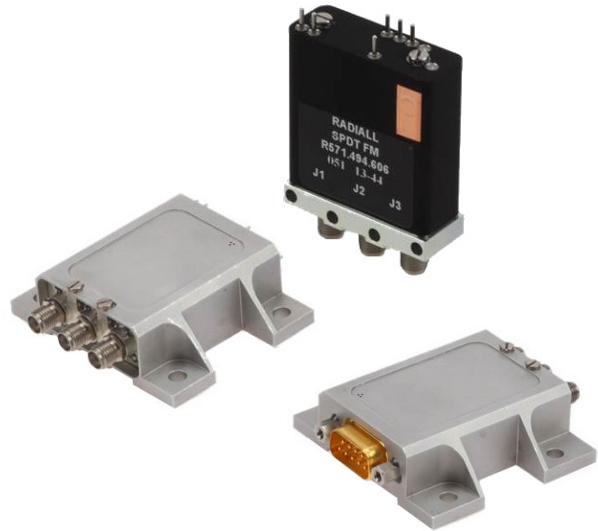
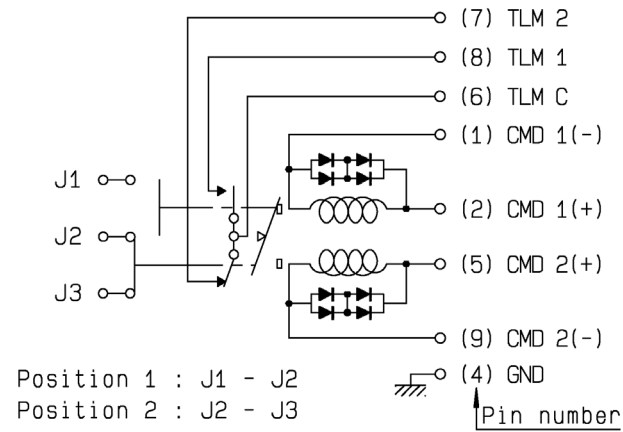

### POWER DERATING GRAPH

Variant 001 to 003: DC to 22 GHz SMA

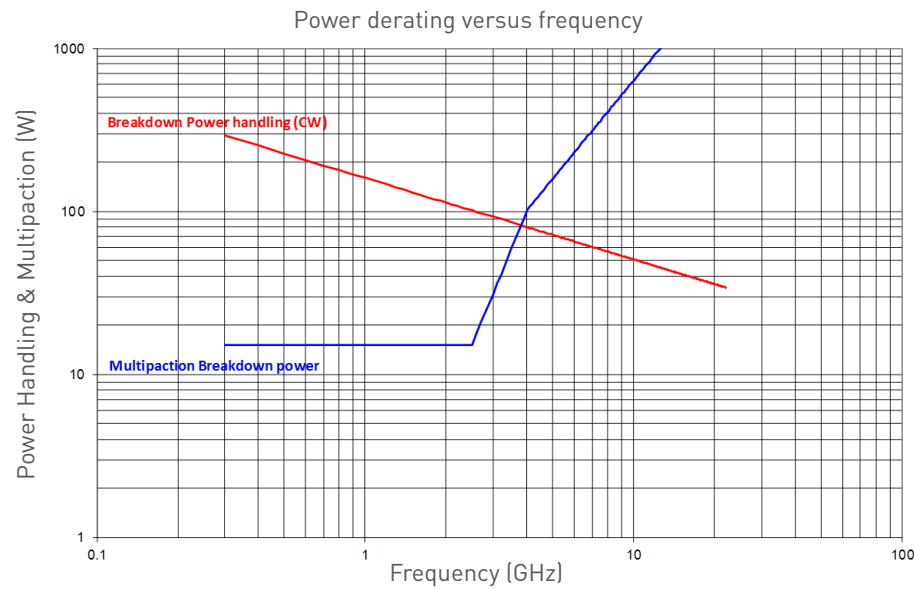

Frequency (GHz)	Breakdown Power Handling (W)	Breakdown Multipaction Power (W)
0.3	292.1	15.2
2.3	105.5	15.2
2.4	103.3	15.2
2.5	101.2	15.2
2.6	99.2	17.8
2.7	97.4	20.7
2.8	95.6	23.9
2.9	94.0	27.5
3.0	92.4	31.5
4.0	80.0	101.6
5.0	71.6	158.8
6.0	65.3	228.6
7.0	60.5	311.2
8.0	56.6	406.4
9.0	53.3	514.4
10.0	50.6	635.0
12.0	46.2	914.5
14.0	42.8	1244.7
16.0	40.0	1625.7
18.0	37.7	2057.5
20.0	35.8	2540.2
22.0	34.1	3073.6

LOW POWER MODELS

## Low Power Coaxial DPDT Switch



LOW-POWER LATCHING COAXIAL DPDT SWITCH according to Radiall specification

### RAD-DET-DPDT-006

- DC to 22 GHz with SMA connectors
- Up to 31 GHz with SMA 2.9 connectors
- Telemetry circuit
- Suppression diodes
- D-Sub or solder pins
- Lay Down or Stand up
- 57 grams and up

## GENERAL SPECIFICATIONS

	Unit	Min	Typical	Max
Actuation Voltage	V	+22	+26	+29
Pick-Up Voltage	V			+20.5
Actuation Current				
@+29V, +25°C	mA		129	139
@+29V, -30°C			164	176
@+29V, +85°C			105	113
Switching Time	ms			25
Pulse Duration	ms	20		1000
Coil Resistance (at +25°C)	Ω	210	225	
RF Contact Resistance	mΩ			100
TLM Indicator Circuit				
Contact Closed	mΩ			1000
Contact Open	MΩ	10		
Contact Current	mA			100
Coil Isolation at 500 VDC	MΩ	10		
Dielectric Withstanding at 50 or 60Hz	Vrms	500		
Mass				
Variant 001-005: C-Switch Stand up D-Sub	grams			80
Variant 002-004: C-Switch Lay Down Pins				57
Variant 003-006: C-Switch Stand up Pins				60

## RF PERFORMANCES

### DC to 22 GHz SMA

Frequency	GHz	DC - 4.2	4.2 - 8.4	8.4 - 14.5	14.5 - 18	18- 20	20- 22
Insertion Loss (max)	dB	0.15	0.25	0.30	0.40	0.50	0.50
VSWR (max)	(dB)	1.20:1	1.25:1	1.25:1	1.33:1	1.33:1	1.40:1
Return Loss (min)		(21)	(19)	(19)	(17)	(17)	(15:6)
Isolation (min)	dB	70			65		
E-Field Shielding Effectiveness (min)	dB	75	70	68	65	60	60

### KA – BAND SMA2.9

Frequency	GHz	17.5-21.5	27.5 - 31
Insertion Loss (max)	dB	0.50	0.65
VSWR (max)	(dB)	1.33:1	1.40:1
Return Loss (min)		(17.7)	(15.6)
Isolation (min)	dB	65	60
E-Field Shielding Effectiveness (min)	dB	60	60
Power Handling (max)	W	10	5

## Low Power Coaxial DPDT Switch

### SCHEMATICS & DRAWINGS

C-Switch, SMA ,Lay Down pins:

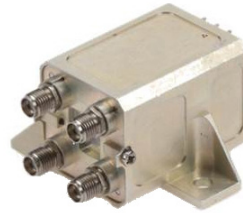
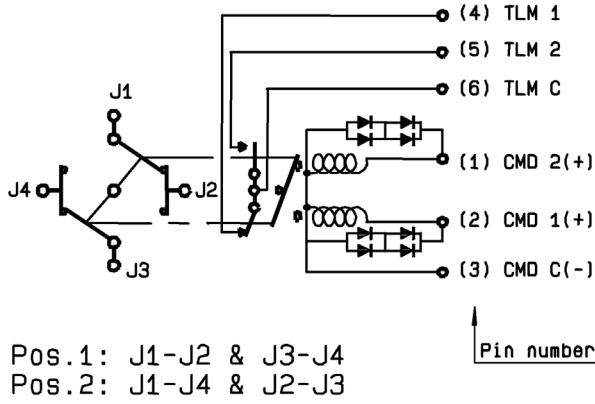

C-Switch, SMA, Stand Up, pins



C-Switch, SMA, Stand Up, D-Sub

### POWER DERATING GRAPH

Variant 001 to 003: DC to 22 GHz SMA

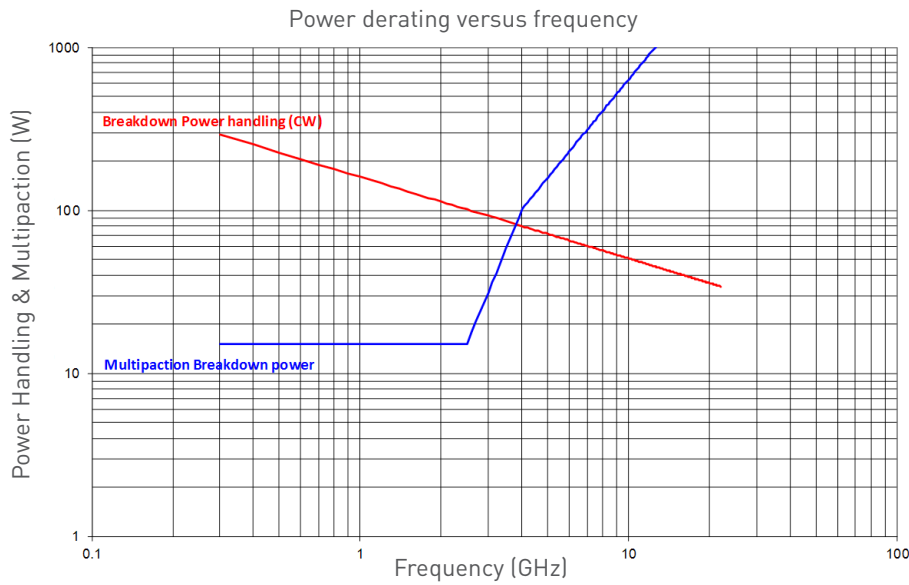

Frequency (GHz)	Breakdown Power Handling (W)	Breakdown Multipaction Power (W)
0.3	292.1	15.2
2.3	105.5	15.2
2.4	103.3	15.2
2.5	101.2	15.2
2.6	99.2	17.8
2.7	97.4	20.7
2.8	95.6	23.9
2.9	94.0	27.5
3.0	92.4	31.5
4.0	80.0	101.6
5.0	71.6	158.8
6.0	65.3	228.6
7.0	60.5	311.2
8.0	56.6	406.4
9.0	53.3	514.4
10.0	50.6	635.0
12.0	46.2	914.5
14.0	42.8	1244.7
16.0	40.0	1625.7
18.0	37.7	2057.5
20.0	35.8	2540.2
22.0	34.1	3073.6

LOW POWER MODELS



## Low Power Coaxial T Switch



**LOW-POWER LATCHING COAXIAL T SWITCH** according to Radiall specification  
**RAD-DET-TSSD-002 and RAD-DET-TSRD-003**

- Random or Sequential drive
- DC to 22 GHz with SMA connectors
- Up to 31 GHz with SMA 2.9 connectors
- Telemetry circuit
- Suppression diodes
- D-Sub or solder pins
- Stand up or Lay Down or fixing plate
- 58 grams and up

### GENERAL SPECIFICATIONS

	Unit	RAD-DET-TSSD-002 Sequential Drive			RAD-DET-TSRD-003 Random Drive		
		Min	Typical	Max	Min	Typical	Max
Actuation Voltage	V	+22	+26	+29	+22	+26	+29
Pick-Up Voltage	V			+20.5			+20.5
Actuation Current	mA						
@+29V, +25°C			345	364		285	305
@+29V, -30°C			439	462		365	390
@+29V, +85°C			280	295		234	250
Switching Time	ms			25			20
Pulse Duration	ms	20		1000	20		1000
Coil Resistance (at +25°C)	Ω	79.8	84		88	95	
RF Contact Resistance	mΩ			100			100
TLM Indicator Circuit							
Contact closed	mΩ			1000			1000
Contact Open	mΩ	10			10		
Contact Current	mA			100			100
Coil Isolation at 500 VDC	MΩ	10			10		
Dielectric Withstanding at 50 or 60Hz	Vrms	500			500		
Mass							
T-Switch, Lay Down Pins	grams			73			64
T-Switch, Stand Up D-Sub				100			-
T-Switch, Stand Up Pins				75			75
T-Switch, Fixing Plate				-			58
Torque Screws for							
Fixing unit	N.m			2.0			2.0
For DC connector				0.44			N/A
For SMA connector		0.8	1.1	1.15	0.8	1.1	1.15

### RF PERFORMANCES

#### DC to 22 GHz SMA

Frequency	GHz	DC-4.2	4.2-5.5	5.5-6.6	6.6-7.7	7.7-8.8	8.8-10.5	10.5-14.5	14.5-17.8	17.8-20	20-22
Insertion Loss (max)	dB	0.15	0.17	0.18	0.21	0.24	0.30	0.35	0.45	0.50	0.50
VSWR (max)	(dB)	1.20:1	1.22:1	1.25:1	1.25:1	1.25:1	1.25:1	1.25:1	1.33:1	1.33:1	1.40:1
Return Loss (min)		(21)	(20)	(19)	(19)	(19)	(19)	(19)	(17)	(17)	(15.6)
Isolation (min)	dB	70						65			
E-Field Shielding Effectiveness (min)	dB	75				70			65		

#### KA – BAND SMA2.9

Frequency	GHz	17.5-21.5	27.5 - 31
Insertion Loss (max)	dB	0.50	0.65
VSWR (max)	(dB)	1.33:1	1.40:1
Return Loss (min)		(17)	(15.6)
Isolation (min)	dB	65	60
E-Field Shielding Effectiveness (min)	dB	60	60
Power Handling (max)	W	10	5

## Low Power Coaxial T Switch

### SCHEMATICS & DRAWINGS

Sequential Drive:

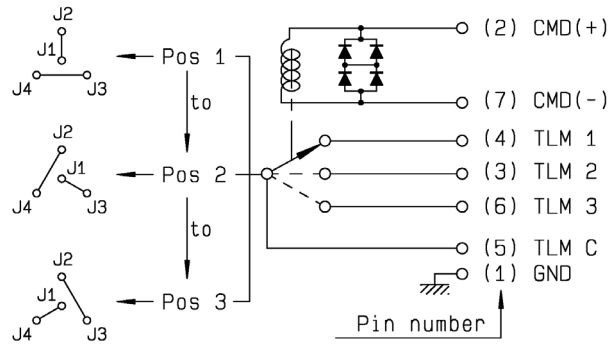

Random Drive:

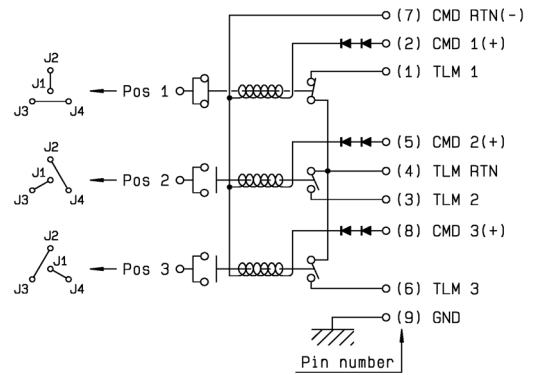

T-Switch, Lay Down with pins:



T-Switch, Stand Up with D-Sub:



T-Switch, Fixing plate with pins:

### POWER DERATING GRAPH

Variant 001 to 003: DC to 22 GHz SMA

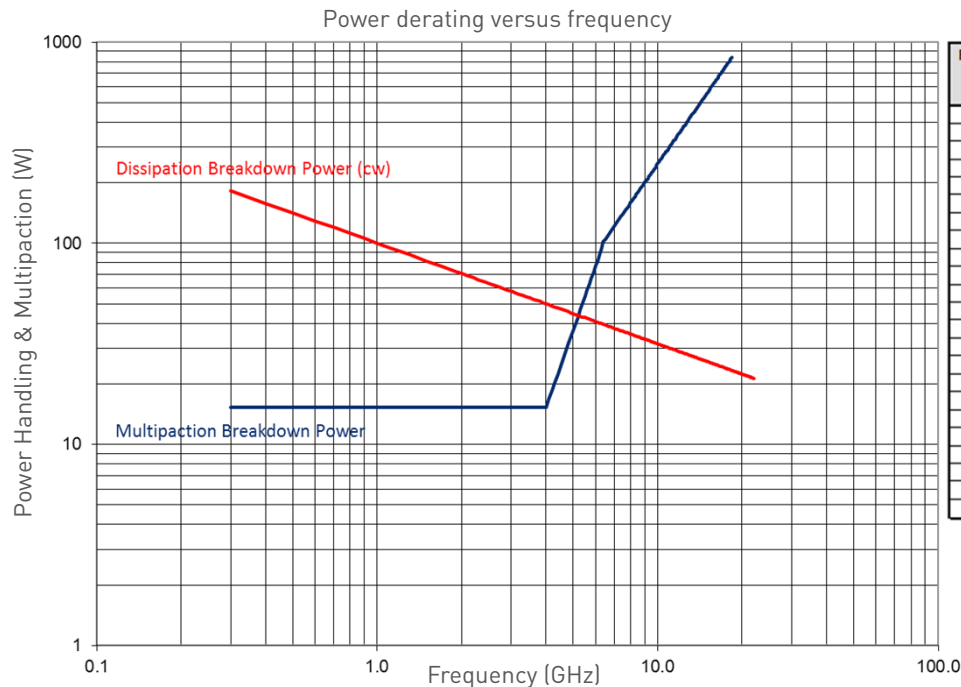

Frequency (GHz)	Breakdown Dissipation Power (W)	Breakdown Multipaction Power (W)
0.3	187.1	15.2
0.4	162.0	15.2
0.5	144.9	15.2
0.6	132.3	15.2
0.7	122.5	15.2
0.8	114.6	15.2
0.9	108.0	15.2
1.0	102.5	15.2
2.0	72.5	15.2
3.0	59.2	15.2
4.0	51.2	15.2
5.0	45.8	37.1
6.0	41.8	77.0
7.0	38.7	121.6
8.0	36.2	158.8
9.0	34.2	200.9
10.0	32.4	248.1
12.0	29.6	357.2
14.0	27.4	486.2
16.0	25.6	635.0
18.0	24.2	803.7
20.0	22.9	992.3
22.0	21.8	1200.6

## Low Power Coaxial DP3T Switch

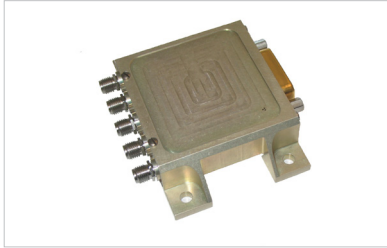

LOW-POWER LATCHING COAXIAL DP3T SWITCH according to Radiall specification

### RAD-DET-DP3T-001

- DC to 22 GHz with SMA connectors
- DC to 31 GHz with SMA 2.9 connectors
- Telemetry circuit
- Suppression diodes
- D-Sub
- Lay Down
- 106 grams

## GENERAL SPECIFICATIONS

	Unit	Min	Typical	Max
Actuation Voltage	V	+22	+26	+29
Pick-Up Voltage	V			+20.5
Actuation Current				
@+29V, +25°C	mA		129	139
@+29V, -30°C			164	176
@+29V, +85°C			105	113
Switching Time	ms			20
Pulse Duration	ms	20		1000
Coil Resistance (at +25°C)	Ω	210	225	
RF Contact Resistance	mΩ			100
TLM Indicator Circuit				
Contact closed	mΩ			1000
Contact Open	MΩ	10		
Contact Current	mA			100
Coil Isolation at 500 VDC	MΩ	10		
Dielectric Withstanding at 50 or 60Hz	V <sub>rms</sub>	500		
Mass	grams			106
Torque Screws for				
Fixing unit				2.0
For DC connector	N.m	0.27		0.44
For SMA connector		0.8	1.1	1.15

## RF PERFORMANCES

### DC to 22 GHz SMA

Frequency	GHz	DC - 4.2	4.2 - 10.7	10.7 - 12.75	12.75 - 14.5	14.5 - 22
Insertion Loss (max)	dB	0.15	0.15	0.25	0.30	0.40
VSWR (max)	(dB)	1.15:1	1.20:1	1.25:1	1.25:1	1.40:1
Return Loss (min)		(23.1)	(20.8)	(19.1)	(19.1)	(15.6)
Isolation (min)	dB	70			60	
E-Field Shielding Effectiveness (min)	dB <sub>i</sub>	75			70	

### KA – BAND SMA2.9

Frequency	GHz	17.5-21.5	21.5 - 27.5	27.5 - 31
Insertion Loss (max)	dB	0.50	0.45	0.65
VSWR (max)	(dB)	1.33:1	1.35:1	1.40:1
Return Loss (min)		(17)	(16.5)	(15.6)
Isolation (min)	dB	65	60	
E-Field Shielding Effectiveness (min)	dB <sub>i</sub>	60	60	
Power Handling (max)	W	10	5	

## Low Power Coaxial DP3T Switch

### SCHEMATICS & DRAWINGS

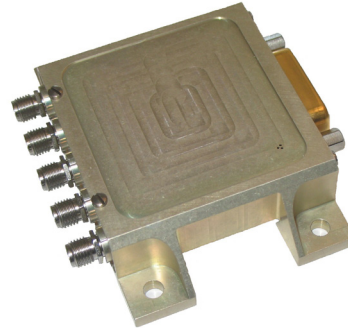
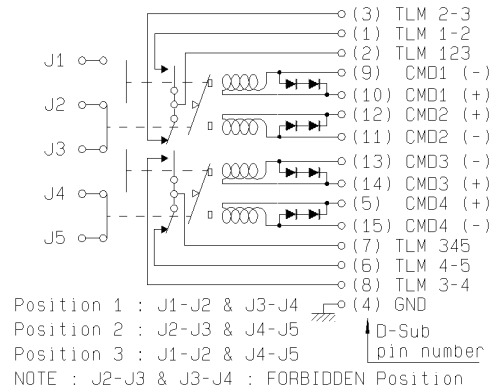

### POWER DERATING GRAPH

Variant 001 to 003: DC to 22 GHz SMA

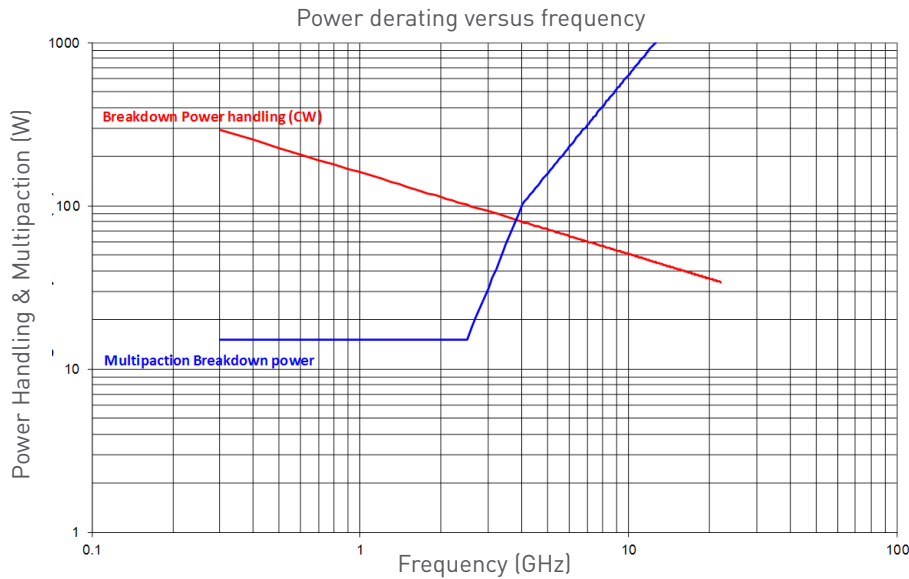

Frequency (GHz)	Breakdown Power Handling (W)	Breakdown Multipaction Power (W)
0.3	292.1	15.2
2.3	105.5	15.2
2.4	103.3	15.2
2.5	101.2	15.2
2.6	99.2	17.8
2.7	97.4	20.7
2.8	95.6	23.9
2.9	94.0	27.5
3.0	92.4	31.5
4.0	80.0	101.6
5.0	71.6	158.8
6.0	65.3	228.6
7.0	60.5	311.2
8.0	56.6	406.4
9.0	53.3	514.4
10.0	50.6	635.0
12.0	46.2	914.5
14.0	42.8	1244.7
16.0	40.0	1625.7
18.0	37.7	2057.5
20.0	35.8	2540.2
22.0	34.1	3073.6

LOW POWER MODELS

## High Power Coaxial SPDT Switch



**HIGH-POWER LATCHING COAXIAL SPDT SWITCH according to Radiall specification RAD-DET-SPDT-002**

- TNC connectors
- Up to 2.2 GHz, with 160 Watts CW
- Up to 4.8 GHz, with 150 Watts CW
- Telemetry circuit
- Suppression diodes
- D-Sub
- Lay Down
- 275 grams

### GENERAL SPECIFICATIONS

	Unit	Min	Typical	Max
Actuation Voltage	V	+20	+26	+30
Pick-Up Voltage	V			+19
Actuation Current	mA			
@+29V, +25°C		178	188	198
@+29V, -30°C		227	239	251
@+29V, +85°C		145	153	161
Switching Time	ms		25	35
Pulse Duration	ms	50		1000
Coil Resistance (at +25°C)	Ω	152	160	168
RF Contact Resistance	mΩ			100
TLM Indicator Circuit				
Contact closed	mΩ			1000
Contact Open	MΩ	2		
Contact Current	mA			100
Coil Isolation at 500 VDC	MΩ	1		
Dielectric Withstanding at 50 or 60Hz	Vrms	500		
Mass	grams			275
variant 001 & 002				
Torque Screws for				
Fixing unit	N.m			2.0
For DC connector				0.2
For SMA connector				2.65

### RF PERFORMANCES

Frequency	GHz	DC - 2.2 GHz Variant 001			DC - 4.8 GHz Variant 002			
		0.04 - 1.0	1.0 - 1.6	1.6 - 2.2	0.04 - 1.0	1.0 - 1.6	1.6 - 2.2	2.2 - 4.8
Insertion Loss (max)	dB		0.12			0.12		0.22
VSWR (max)	(dB)		1.20:1			1.20:1		1.38:1
Return Loss (min)			[20.8]			[20.8]		[15.9]
Isolation (min)	dB		70			70		
E-Field Shielding Effectiveness (min)	dB		70			70		60
Power Handling (max)	W	33 @ 1 GHz	85 @ 1.6 GHz	160 @ 2.2 GHz	5 @ 1 GHz	29 @ 1.6 GHz	55 @ 2.2 GHz	102 @ 3 GHz

## High Power Coaxial SPDT Switch

### SCHEMATICS & DRAWINGS

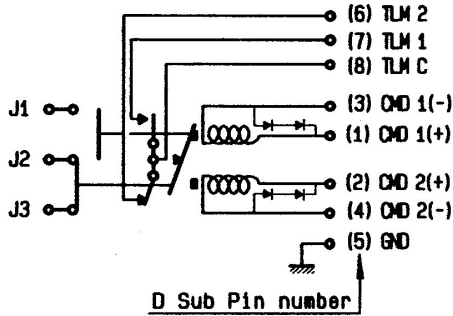

Position 1 : J1 - J2  
Position 2 : J2 - J3

SPDT Switch, Lay Down, D-Sub, variant 001 & 002:



### POWER DERATING GRAPH

Variant 001, High Cavity

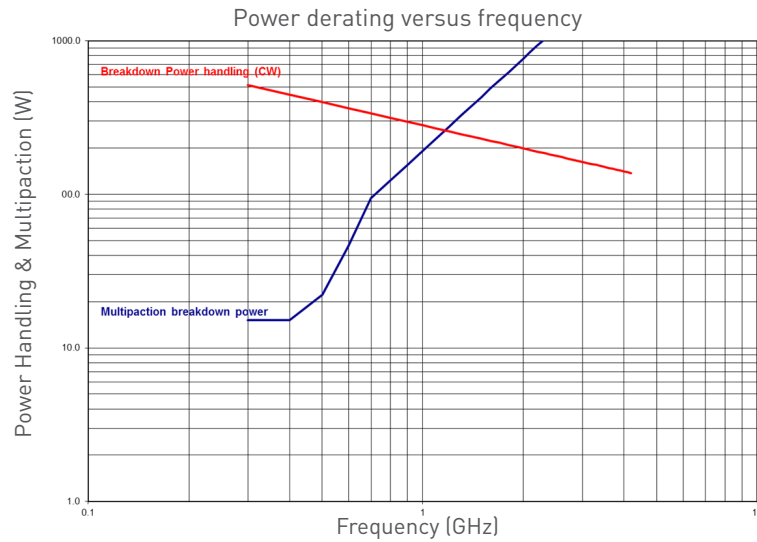

Frequency (GHz)	Breakdown Power handling (W)	Breakdown Multipaction Power (W)
0.3	514.7	15.2
0.4	445.8	15.2
0.5	398.7	22.3
0.6	364.0	46.2
0.7	337.0	94.1
0.8	315.2	122.9
0.9	297.2	155.6
1.0	281.9	192.1
1.1	268.8	232.4
1.2	257.4	276.6
1.3	247.3	324.6
1.4	238.3	376.5
1.5	230.2	432.2
1.6	222.9	491.8
1.7	216.2	555.2
1.8	210.1	622.4
1.9	204.5	693.5
2.0	199.4	768.4
2.2	190.1	929.8
2.4	182.0	1106.5
2.6	174.8	1296.6
2.8	168.5	1506.1
3.0	162.8	1728.9
3.5	150.7	2353.2
4.0	141.0	3073.6
4.2	137.6	3388.6

Variant 002, Standard Cavity

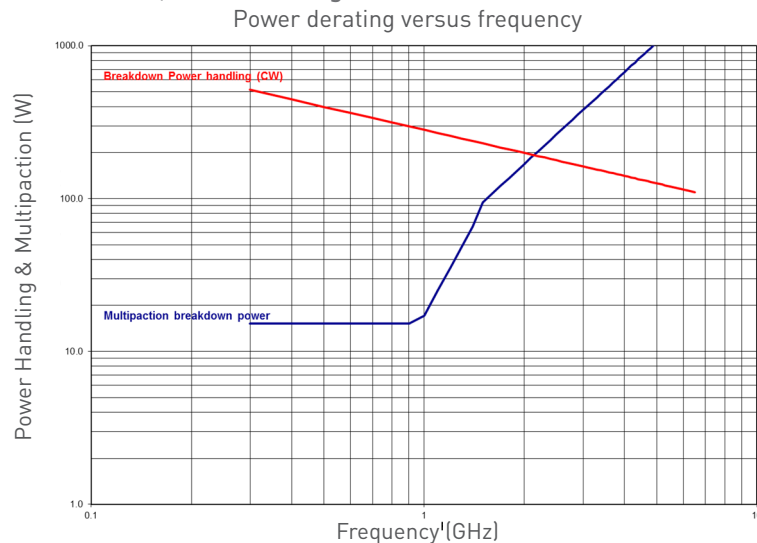

Frequency (GHz)	Breakdown Power handling (W)	Breakdown Multipaction Power (W)
0.3	514.7	15.2
0.9	297.2	15.2
1.0	281.9	17.1
1.1	268.8	25.1
1.2	257.4	35.5
1.3	247.3	48.9
1.4	238.3	65.8
1.5	230.2	94.7
1.6	222.9	107.8
1.7	216.2	121.7
1.8	210.1	136.4
1.9	204.5	152.0
2.0	199.4	168.4
2.2	190.1	203.8
2.4	182.0	242.5
2.6	174.8	284.6
2.8	168.5	330.1
3.0	162.8	379.0
3.2	157.6	431.2
3.4	152.9	486.8
3.6	148.6	545.7
3.8	144.6	608.0
4.0	141.0	673.7
4.2	137.6	742.8
4.4	134.4	815.2
4.6	131.4	891.0
4.8	128.7	970.1
5.0	126.1	1052.7
5.5	120.2	1213.7
6.0	115.1	1515.9
6.5	110.6	1779.0

## High Power Coaxial DP3T Switch

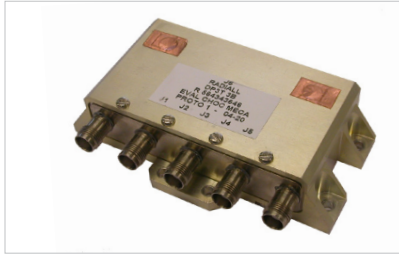

### HIGH-POWER LATCHING COAXIAL DP3T SWITCH according to Radiall specification RAD-DET-DP3T-002

- TNC connectors
- Up to 2.2 GHz, with 160 Watts CW
- Up to 4.8 GHz, with 150 Watts CW
- Telemetry circuit
- Suppression diodes
- D-Sub or pins
- Lay Down
- 390 grams and up

### GENERAL SPECIFICATIONS

	Unit	Min	Typical	Max
Actuation Voltage	V	+20	+26	+30
Pick-Up Voltage	V			+19
Actuation Current	mA			
@+29V, +25°C		178	188	198
@+29V, -30°C		227	239	251
@+29V, +85°C		145	153	161
Switching Time	ms		25	35
Pulse Duration	ms	50		1000
Coil Resistance (at +25°C)	Ω	152	160	168
RF Contact Resistance	mΩ			100
TLM Indicator Circuit				
Contact closed	mΩ			1000
Contact Open	MΩ	2		
Contact Current	mA			100
Coil Isolation at 500 VDC	MΩ	1		
Dielectric Withstanding at 50 or 60Hz	Vrms	500		
Mass	grams			460
Variant 001: Lay Down D-Sub				445
Variant 002: Lay Down D-Sub				390
Variant 003: Lay Down pins				
Torque Screws for	N.m			
Fixing unit				2.0
For DC connector				0.2
For SMA connector				2.65

### RF PERFORMANCES

Frequency	GHz	DC - 2.2 GHz Variant 001			DC - 4.8 GHz Variant 002 and 003			
		0.04 - 1.0	1.0 - 1.6	1.6 - 2.2	0.04 - 1.0	1.0 - 1.6	1.6 - 2.2	2.2 - 4.8
Insertion Loss (max)	dB	0.12			0.12			0.22
VSWR (max)	(dB)	1.20:1			1.20:1			1.38:1
Return Loss (min)		{20.8}			{20.8}			{15.9}
Isolation (min)	dB	70			70			
E-Field Shielding Effectiveness (min)	dB	70			70			60
Power Handling (max)	W	33 @ 1 GHz	85 @ 1.6 GHz	160 @ 2.2 GHz	5 @ 1 GHz	29 @ 1.6 GHz	55 @ 2.2 GHz	102 @ 3 GHz

## High Power Coaxial DP3T Switch

### SCHEMATICS & DRAWINGS

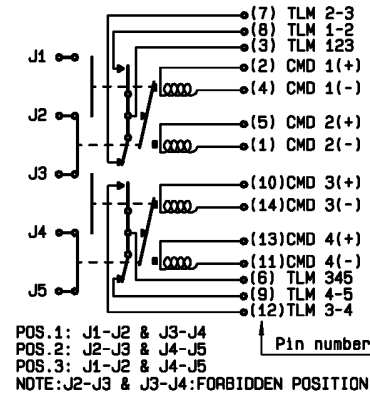

DP3T Switch, Lay Down, Pins:

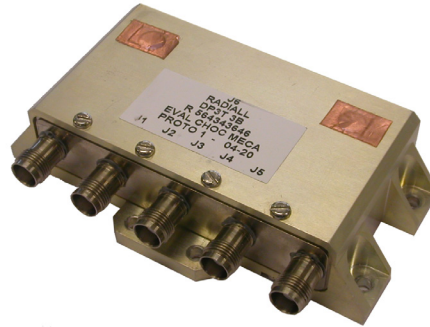

### POWER DERATING GRAPH

Variant 1, High Cavity

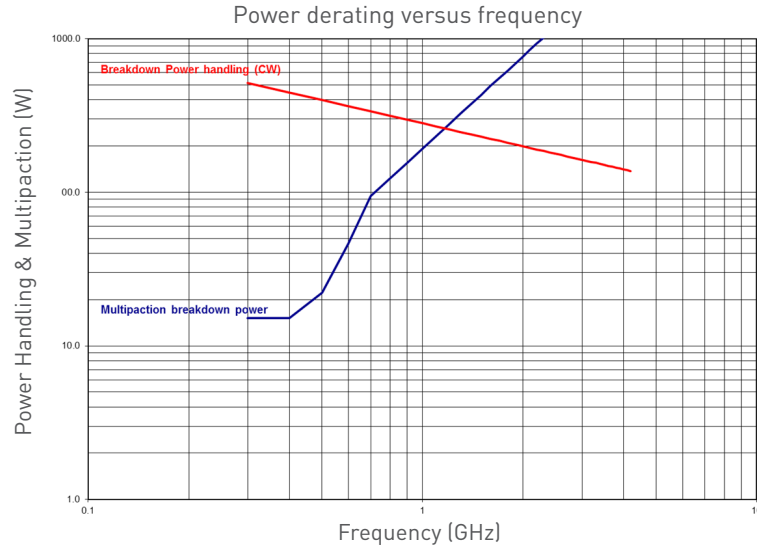

Frequency (GHz)	Breakdown Power handling (W)	Breakdown Multipaction Power (W)
0.3	514.7	15.2
0.4	445.8	15.2
0.5	398.7	22.3
0.6	364.0	46.2
0.7	337.0	94.1
0.8	315.2	122.9
0.9	297.2	155.6
1.0	281.9	192.1
1.1	268.8	232.4
1.2	257.4	276.6
1.3	247.3	324.6
1.4	238.3	376.5
1.5	230.2	432.2
1.6	222.9	491.8
1.7	216.2	555.2
1.8	210.1	622.4
1.9	204.5	693.5
2.0	199.4	768.4
2.2	190.1	929.8
2.4	182.0	1106.5
2.6	174.8	1296.6
2.8	168.5	1506.1
3.0	162.8	1728.9
3.5	150.7	2353.2
4.0	141.0	3073.6
4.2	137.6	3388.6

Variant 002, Standard Cavity

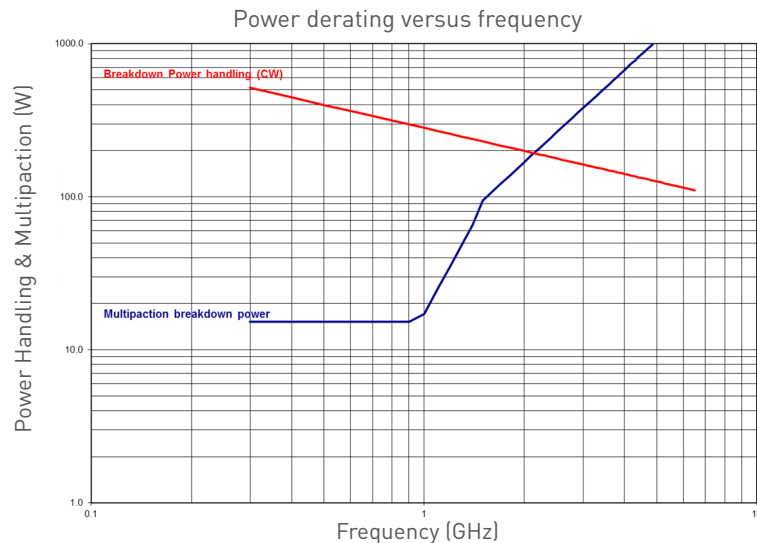

Frequency (GHz)	Breakdown Power handling (W)	Breakdown Multipaction Power (W)
0.3	514.7	15.2
0.9	297.2	15.2
1.0	281.9	17.1
1.1	268.8	25.1
1.2	257.4	35.5
1.3	247.3	48.9
1.4	238.3	65.8
1.5	230.2	94.7
1.6	222.9	107.8
1.7	216.2	121.7
1.8	210.1	136.4
1.9	204.5	152.0
2.0	199.4	168.4
2.2	190.1	203.8
2.4	182.0	242.5
2.6	174.8	284.6
2.8	168.5	330.1
3.0	162.8	379.0
3.2	157.6	431.2
3.4	152.9	486.8
3.6	148.6	545.7
3.8	144.6	608.0
4.0	141.0	673.7
4.2	137.6	742.8
4.4	134.4	815.2
4.6	131.4	891.0
4.8	128.7	970.1
5.0	126.1	1052.7
5.5	120.2	1213.7
6.0	115.1	1515.9
6.5	110.6	1779.0

HIGH POWER MODELS



## High Power Coaxial T Switch



### HIGH-POWER LATCHING COAXIAL T SWITCH according to Radiall specification RAD-DET-TSRD-002

- TNC connectors
- DC to 8 GHz
- Up to 120 Watts CW @ 4 GHz
- Random Drive
- Telemetry circuit
- Suppression diodes
- D-Sub or solder pins
- Lay Down or Stand up
- 355 grams and up

### GENERAL SPECIFICATIONS

	Unit	Min	Typical	Max
Actuation Voltage	V	+22	+26	+29
Pick-Up Voltage	V			+20.5
Actuation Current	mA			
@+29V, +25°C		450	470	490
@+29V, -25°C		555	585	610
@+29V, -30°C		570	595	620
@+29V, +80°C		360	385	405
@+29V, -85°C	365	380	397	
Switching Time	ms			35
Pulse Duration	ms	35		1000
Coil Resistance (at +25°C)	Ω	59.3	61.8	64.4
RF Contact Resistance	mΩ			100
TLM Indicator Circuit				
Contact closed	mΩ			1000
Contact Open	MΩ	1		
Contact Current	mA			100
Coil Isolation at 500 VDC	MΩ	1		
Dielectric Withstanding at 50 or 60Hz	Vrms	500		
Mass	grams			360
T-Switch, Lay Down, D-Sub				355
T-Switch, Stand Up, D-Sub				
Torque Screws for	N.m			
Fixing unit				2.0
For DC connector				0.44
For SMA connector				2.65

### RF PERFORMANCES

#### DC - 8 GHz Variants 001 & 002

Frequency	GHz	DC - 2	2 - 4.8	4.8 - 6	6 - 8
Insertion Loss (max)	dB	0.17	0.20	0.30	0.40
VSWR (max)	(dB)	1.10:1	1.25:1	1.35:1	1.50:1
Return Loss (min)		[26.4]	[19.1]	[16.5]	[14]
Isolation (min)	dB	70			
E-Field Shielding Effectiveness (min)	dBi	75			70

## High Power Coaxial T Switch

### SCHEMATICS & DRAWINGS

T-Switch, TNC, D-Sub, variant 001 & 002:

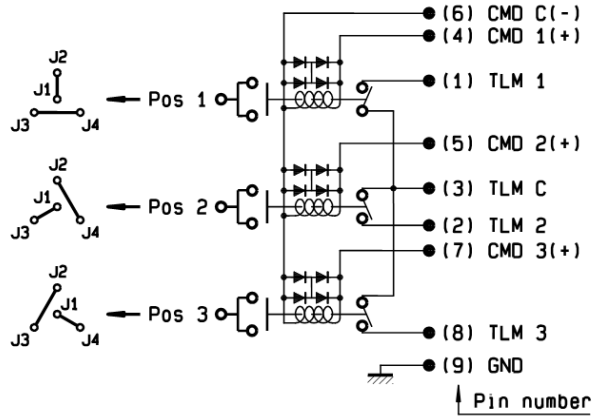

T-Switch, Lay Down, D-Sub, variant 001:



T-Switch, Stand Up, D-Sub, variant 002:



### POWER DERATING GRAPH

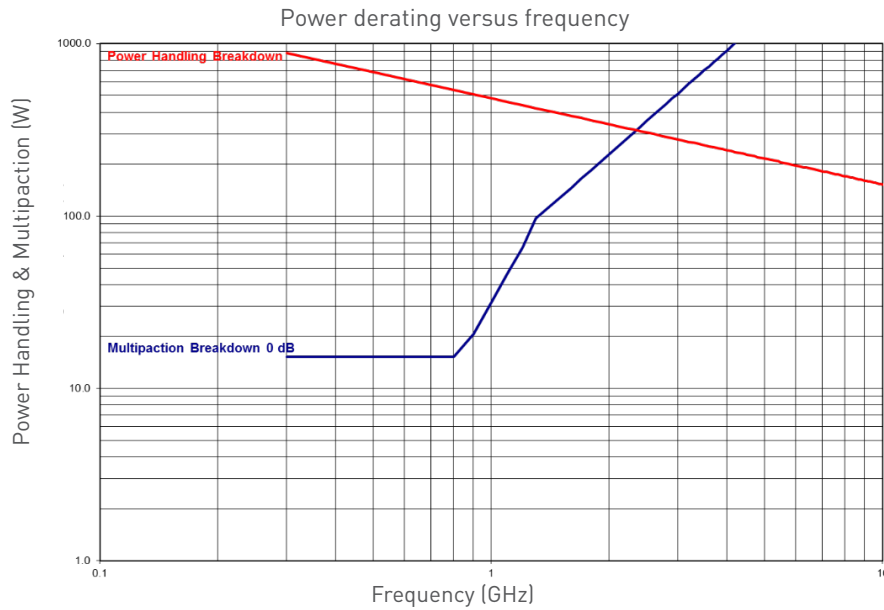

Frequency (GHz)	Breakdown Power Handling (W)	Breakdown Multipaction Power (W)
0.3	880.0	15.2
0.4	762.1	15.2
0.5	681.6	15.2
0.6	622.3	15.2
0.7	576.1	15.2
0.8	538.9	15.2
0.9	508.1	20.7
1	482.0	31.5
1.1	459.6	46.2
1.2	440.0	65.4
1.3	422.7	96.6
1.4	407.4	112.0
1.5	393.5	128.6
1.6	381.1	146.3
1.7	369.7	165.2
1.8	359.3	185.2
1.9	349.7	206.3
2	340.8	228.6
2.1	332.6	252.0
2.2	325.0	276.6
2.3	317.8	302.3
2.4	311.1	329.2
2.5	304.8	357.2
2.6	298.9	386.4
2.7	293.3	416.6

## Thermal Vacuum Switches for Ground Segments



With more than 25 years of experience in the space industry, Radiall has developed a product offering that emphasizes reliability and performance. The latest addition to the range includes SPDT, DPDT and SPnT RF switches designed to operate in thermal vacuum environments. These products can be mounted on ground based test benches, used in test equipment, and space vacuum conditions.

Tvac Series switches are designed in accordance with our standard RAMSES product offering and offer identical configurations with excellent performance.

### PART NUMBER SELECTION

6 standard models are available for test benches dedicated to space equipment in Thermal Vacuum environment:

- 22 GHz SPDT coaxial switch: R571 F63 121
- 22 GHz DPDT coaxial switch: R578 F63 121
- 22 GHz non terminated SP6T coaxial switch: R583 F33 121
- 40 GHz SPDT coaxial switch: R571 863 121
- 40 GHz DPDT coaxial switch: R578 863 121
- 40 GHz non terminated SP6T coaxial switch: R583 833 121

Operating mode	Latching	
Nominal operating voltage (across operating temperature)	Vdc	28 (24/30)
Coil resistance (+/-10%)	Ω	DPDT and SP6T: 225 / SPDT: 350
Nominal operating current at 23°	mA	DPDT and SP6T: 125 / SPDT: 80
Average power (Thermal vacuum condition)	See Power rating chart on page 7-20	
Switching time (max)	SPDT and DPDT: 10ms / SP6T: 15ms	
SMA - SMA 2.9	SPDT	10 million cycles
SMA - SMA 2.9	DPDT	2.5 million cycles
SMA - SMA 2.9	SP6T	5 million cycles / 2 million cycles
Connectors (1)	SMA / SMA2.9	

(1) connector SMA 2.9 is equivalent to "K connector®", registered trademark of Anritsu.

## Thermal Vacuum Switches

### ADDITIONAL SPECIFICATION

Polarity		Positive Common
Actuator terminals	SPDT	Solder Pins
	DPDT	Male 9 pins D-Sub connector
	SP6T	Male 25 pins D-Sub connector
Operating temperature range		-40°C to 85°C
Storage temperature range		-55°C to 85°C
Construction		Thermal Vacuum compatible

### SMA CONNECTOR

Switch model	Frequency range GHz	V.S.W.R. (max)	Insertion loss (max) dB	Isolation (min) dB	Impedance $\Omega$	Average power(1) W	Repeatability	
SPDT	DC - 22	DC - 3	1.20	0.20	80	50	240	0.03 dB peak change in Insertion Loss over 100 cycles
		3 - 8	1.30	0.30	70		150	
		8 - 12.4	1.40	0.40	60		120	
		12.4 - 18	1.50	0.50	60		100	
		18 - 22	1.70	0.70	55		40	
DPDT SP6T (non terminated)	DC - 22	DC - 3	1.20	0.20	80	50	240	
		3 - 8	1.30	0.30	70		150	
		8 - 12.4	1.40	0.40	60		120	
		12.4 - 18	1.50	0.50	60		100	
		18 - 22	1.70	0.70	50		40	

### SMA2.9 CONNECTOR

Switch model	Frequency range GHz	V.S.W.R. (max)	Insertion loss (max) dB	Isolation (min) dB	Impedance $\Omega$	Average power (1) W	Repeatability	
SPDT DPDT	DC - 40	DC - 6	1.30	0.30	70	50	80	0.03 dB peak change in Insertion Loss over 100 cycles
		6 - 12.4	1.40	0.40	60		60	
		12.4 - 18	1.50	0.50	60		50	
		18 - 26.5	1.70	0.70	55		20	
		26.5 - 40	1.90	0.90	50		10	
SP6T (non terminated)	DC - 40	DC - 6	1.30	0.30	70	50	40	
		6 - 12.4	1.40	0.40	60		30	
		12.4 - 18	1.50	0.50	60		25	
		18 - 26.5	1.70	0.70	55		15	
		26.5 - 40	1.90	0.90	50		5	

(1): Average power at 25°C per RF path / Sea level.

### WHY A THERMAL VACUUM TEST BENCH ?

- It limits the need of hermetic adaptors and cable assemblies
- It improves RF performance
- It decreases the complexity of the Test bench

## Thermal Vacuum Switches

### POWER DERATING GRAPH

#### SMA22 GHz

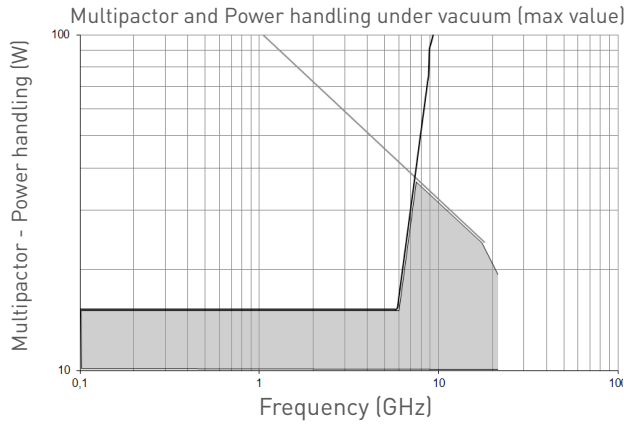

SPDT, DPDT and SP6T products

- Power Handling
- Multipactor
- Aver. Power Capability

#### SMA2.9 40 GHz

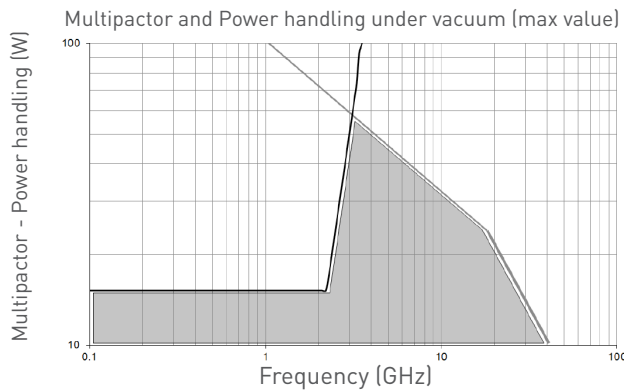

SPDT and DPDT products

- Power Handling
- Multipactor
- Aver. Power Capability

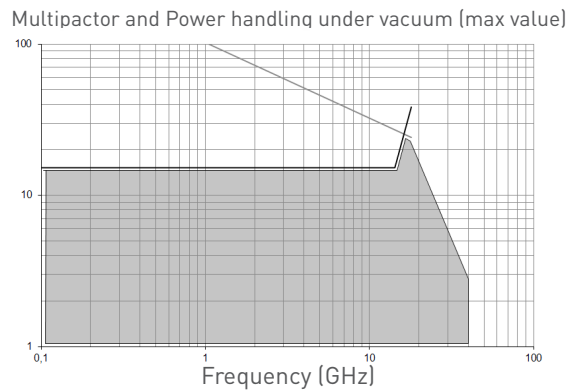

SP6T products

- Power Handling
- Multipactor
- Aver. Power Capability

### HERMETIC FEMALE / FEMALE ADAPTATORS

- SMA DC - 18 GHz
- TNC DC - 11 GHz
- ESA qualified
- High reliability

