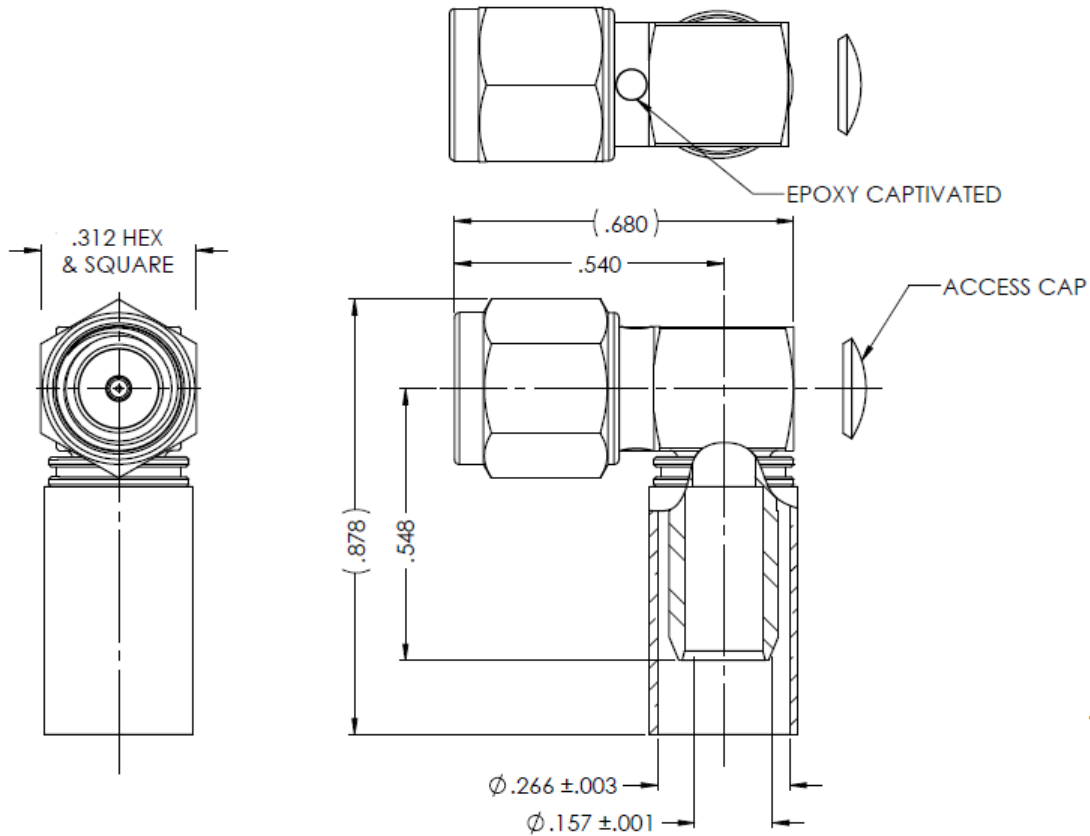
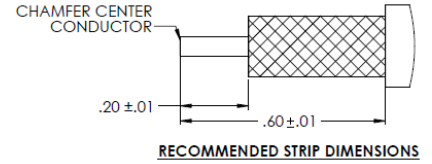

**NOTICE OF PROPRIETARY RIGHTS** THIS DOCUMENT CONTAINS CONFIDENTIAL TECHNICAL DATA, INCLUDING TRADE SECRETS, PROPRIETARY TO TIMES MICROWAVE SYSTEMS. DISCLOSURE OF THIS DATA IS EXPRESSLY CONDITIONED UPON YOUR ASSENT THAT ITS USE IS LIMITED TO USE WITHIN YOUR COMPANY ONLY. ANY OTHER USE IS STRICTLY PROHIBITED WITHOUT THE PRIOR WRITTEN CONSENT OF TIMES MICROWAVE SYSTEMS.

SYM	REVISION DESCRIPTION	DFTM	DATE	APPD	DATE
A	RELEASED FOR PRODUCTION	N. N. N	11/7/13	J. D. B.	11/7/13

**Australian Representatives**  
**ROJONE, PTY LTD.**  
 Tel: 02 9829 1555  
 E: sales@rojone.com.au  
 www.rojone.com.au

**NOTES:**

- ASSEMBLED CONNECTOR INTERFACE IS DESIGNED IN ACCORDANCE WITH MIL-STD-348.
- MATERIAL:**  
 BODY, NUT - STAINLESS STEEL PER ASTM 582, S30300 ALLOY, COND. A  
 INSULATOR - TEFLON PER ASTM D1710, TYPE 1, GRADE 1, CLASS A  
 CONTACT - BRASS PER ASTM B16, C36000 ALLOY, TEMPER H02  
 GASKET - SILICON RUBBER PER A-A-59588, 50-75 DUROMETER  
 SHRINK SLEEVE - HEAT SHRINKABLE ATUM PER MIL-I-23053/4 (NOT SHOWN)  
 CRIMP SLEEVE - D.H.P. COPPER CDA, ALLOY #122, TEMPER HARD  
 LOCKING RING - BERYLLIUM COPPER PER ASTM B196, C17300 ALLOY, CONDITION HT
- FINISH:**  
 CONTACT - GOLD PLATE PER ASTM B488  
 CRIMP SLEEVE - SULFAMATE NICKEL PER MIL-P-27418  
 ALL OTHER METAL PARTS - PASSIVATE PER SAE-AMS-2700

MATL:	UNLESS OTHERWISE SPECIFIED		DFTM. N. N. N	TIMES MICROWAVE SYSTEMS
	ALL DIMENSIONS ARE IN INCHES MACHINED SURFACES FINISH 63 RMS MAX. REMOVE ALL BURRS .004 MAX. BREAK MACHINE CORNERS .005 MAX. FILLET R. TOLERANCES ON DECIMALS . XX ± .01 . XXX ± .005 ANGLES ± 1° FRACTIONS ± 1/64		DATE 11/7/13	
USED ON: C			CHKD. J. D. B.	
			DATE 11/7/13	
			APPD. J. D. B.	
SCALE: NONE	DWG. SIZE A	DO NOT SCALE DRAWING	CODE IDENT 68999	DATE 11/7/13
			DATE 11/7/13	1 of 1   SD3190-2900   A