

NOTICE OF PROPRIETARY RIGHTS THIS DOCUMENT CONTAINS CONFIDENTIAL TECHNICAL DATA, INCLUDING TRADE SECRETS, PROPRIETARY TO TIMES MICROWAVE SYSTEMS. DISCLOSURE OF THIS DATA IS EXPRESSLY CONDITIONED UPON YOUR ASSENT THAT ITS USE IS LIMITED TO USE WITHIN YOUR COMPANY ONLY. ANY OTHER USE IS STRICTLY PROHIBITED WITHOUT THE PRIOR WRITTEN CONSENT OF TIMES MICROWAVE SYSTEMS.

SYM	REVISION DESCRIPTION	DFTM	DATE	APPD	DATE
-	RELEASED FOR PRODUCTION	J. C. L.	6/6/96	J. C. L.	6/6/96
A	CHANGED PER CDC #30773	D. J. H.	10/7/09	J. D. B.	10/9/09
B	CHANGED PER CDC #35863	D. J. H.	10/24/12	J. D. B.	10/29/12

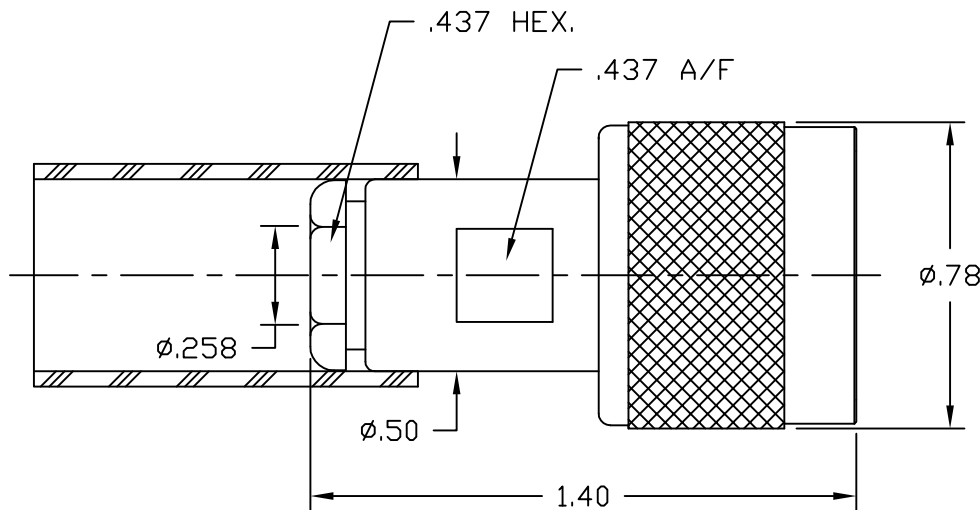

Australian Representatives
ROJONE, PTY LTD.
 Tel: 02 9829 1555
 E: sales@rojone.com.au
 www.rojone.com.au

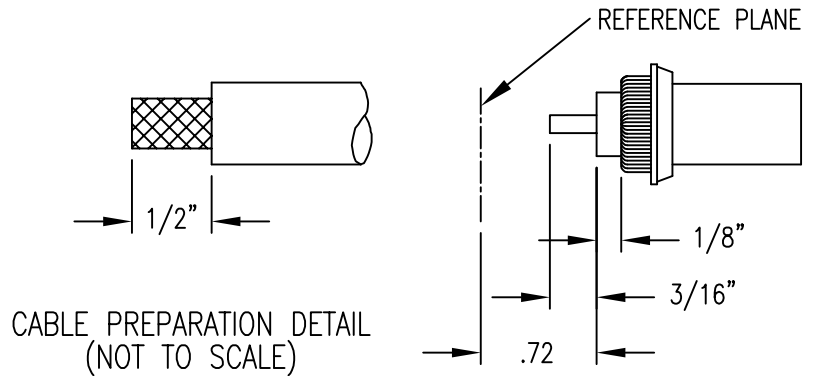

- | | |
|--|--|
| 1.0 PERFORMANCE | 2.3 LOCKING RING: PHOSPHOR BRONZE, ASTM-B-159, ALLOY 510 |
| 1.1 FREQUENCY RANGE: DC-11GHz | 2.4 OTHER METAL PARTS: BRASS, ASTM-B-16 |
| 1.2 VOLTAGE RANGE: 1000V RMS (sea level) | 2.5 GASKETS: SILICON RUBBER, ZZ-R-765, GR. 50, RED |
| 1.3 NOMINAL IMPEDANCE: 50 OHMS | 2.6 HEAT SHRINK: ATUM, HEAVY WALL, ϕ .50 X 1.25 |
| 1.4 DWV: 2500V RMS @ 60Hz (sea level) | 3.0 FINISHES |
| 1.5 TEMPERATURE RANGE: -65°C TO +165°C | 3.1 CENTER CONTACT: GOLD PLATED |
| 2.0 MATERIALS | 3.2 ALL OTHER METAL PARTS: SILVER PLATED |
| 2.1 DIELECTRIC: TEFLON, ASTM-D-1710 | 4.0 MECHANICAL |
| 2.2 CENTER CONTACT: BRASS, ASTM-B-16 | 4.1 INTERFACE IN ACCORDANCE WITH MIL-STD-348 |

MATL:	UNLESS OTHERWISE SPECIFIED ALL DIMENSIONS ARE IN INCHES MACHINED SURFACES FINISH 32 RMS MAX. REMOVE ALL BURRS .005 MAX. BREAK MACHINE CORNERS .005 MAX. FILLET R. TOLERANCES ON DECIMALS .XX ± .03 .XXX ± .005 ANGLES ± 1° FRACTIONS ± 1/32	DFTM. J. C. L.	TIMES MICROWAVE SYSTEMS
		DATE 6/6/96	
USED ON: B		CHKD. J. C. L.	TC-240-NMC TYPE "N" MALE, CLAMP FOR LMR-240
		DATE 6/6/96	
SCALE: NONE	DWG. SIZE A	APPD. J. C. L.	SHEET 1 of 1
		DATE 6/6/96	
DO NOT SCALE DRAWING	CODE IDENT 68999	DATE 6/6/96	REV B