

LTR	DESCRIPTION	DATE	BY
-	Released	6/20/96	JCL

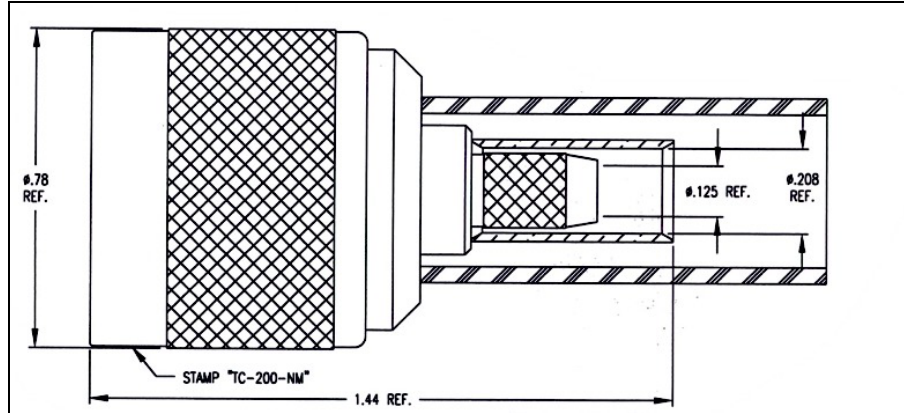

**I. MATERIALS & FINISHES**

center contact: Gold (30u")Plated Brass  
 outer contact: Silver (200 u")Plated Brass  
 coupling nut: Silver (200 u")Plated Brass  
 body: Silver (200 u")Plated Brass  
 crimp sleeve: Silver (200 u")Plated Copper  
 dielectric: Teflon® PTFE  
 gasket: Silicone Rubber  
 shrink sleeve: Adhesive Lined Polyolefin  
 attachment: braid crimp (.213"hex)

**II. ELECTRICAL PROPERTIES**

impedance: 50 ohms  
 working voltage: 1000 vrms (max)  
 vswr: 1.25:1 (max) up to 3 GHz  
 insertion loss: 0.10 x √Fghz

Australian Representatives  
**ROJONE**, PTY LTD.  
 Tel: 02 9829 1555  
 E: sales@rojone.com.au  
 www.rojone.com.au

Unless otherwise specified, dimensions are in inches. Tolerances are applicable when specified.

These drawings and specifications contain proprietary information which is the property of Times Microwave Systems.

Approvals		
Drawn	JCL	6/20/96

**TIMES MICROWAVE SYSTEMS**  
 Wallingford, CT 06492  
 (203) 949-8400; (203) 949-8423.Fax  
 www.timesmicrowave.com

**TC-200-NM**  
 Type-N male (plug) – Solder Pin  
 for LMR-200 Cable

Size A	CAGE CODE <b>68999</b>	Drawing No.: <b>3190-224</b>
--------	---------------------------	---------------------------------

Scale: NA	Rev. (-)	Sheet: 1 of 1
-----------	----------	---------------