

NOTICE OF PROPRIETARY RIGHTS THIS DOCUMENT CONTAINS CONFIDENTIAL TECHNICAL DATA, INCLUDING TRADE SECRETS, PROPRIETARY TO TIMES MICROWAVE SYSTEMS. DISCLOSURE OF THIS DATA IS EXPRESSLY CONDITIONED UPON YOUR ASSENT THAT ITS USE IS LIMITED TO USE WITHIN YOUR COMPANY ONLY. ANY OTHER USE IS STRICTLY PROHIBITED WITHOUT THE PRIOR WRITTEN CONSENT OF TIMES MICROWAVE SYSTEMS.

SYM	REVISION DESCRIPTION	DFTM	DATE	APPD	DATE
-	RELEASED FOR PRODUCTION	J. C. L.	8/20/03	J. C. L.	8/20/03
A	CHANGED PER CDC #36704	D. J. H.	1/14/13	J. D. B.	1/15/13

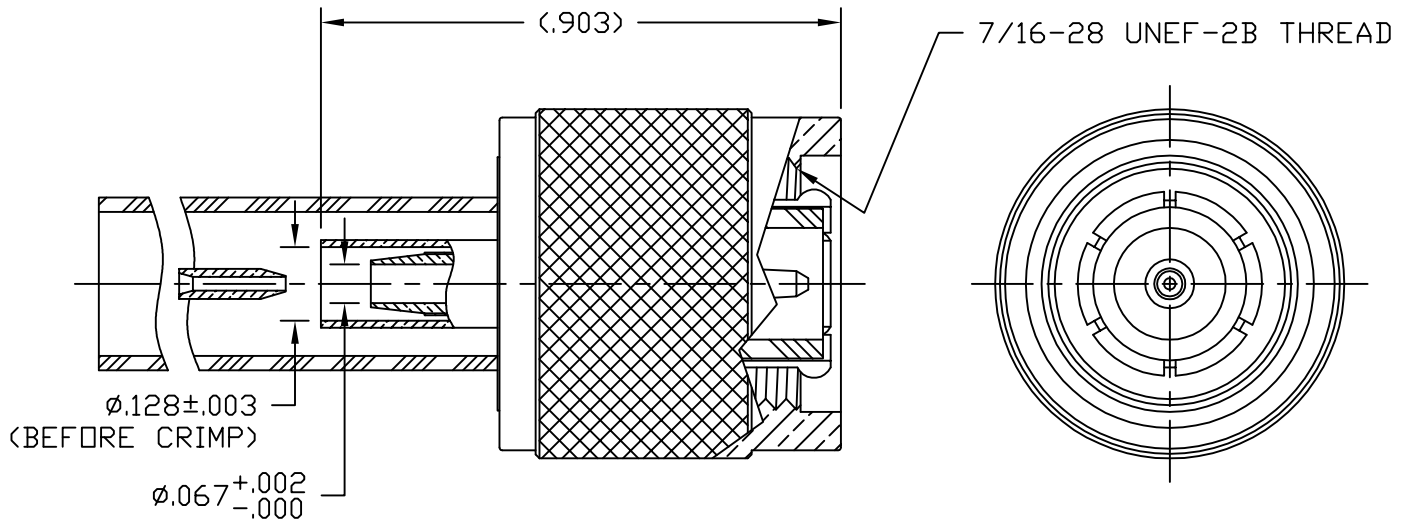

NOTES:

- ASSEMBLED CONNECTOR INTERFACE IS DESIGNED IN ACCORDANCE WITH MIL-STD-348.
- MATERIAL: BODY & NUT - BRASS PER ASTM B16.
CONTACT FINGERS & CONTACTS - BERYLLIUM COPPER PER ASTM B196.
INSULATOR - TEFLON PER ASTM D1710.
CRIMP SLEEVE - D.H.P. COPPER CDA ALLOY 122.
RETAINING RING - PHOSPHOR BRONZE PER QQ-B-750.
GASKET - SILICONE RUBBER PER ZZ-R-765.
SHRINK SLEEVE - SHRINKABLE POLYOLEFIN PER MIL-I-23053/5.
- FINISHES: RETAINING RING - NOT PLATED.
CONTACTS - GOLD PLATE PER MIL-G-45204.
ALL OTHER METAL PARTS - SILVER PLATE PER QQ-S-365.
- CONTACT PIN IS SOLDERED.
- CRIMP THE FERRULE TO .128" HEX.

Australian Representatives
ROJONE, PTY LTD.
 Tel: 02 9829 1555
 E: sales@rojone.com.au
 www.rojone.com.au

MATERIAL:	UNLESS OTHERWISE SPECIFIED ALL DIMENSIONS ARE IN INCHES MACHINED SURFACES FINISH N/A RMS MAX. REMOVE ALL BURRS .005 MAX. BREAK MACHINE CORNERS .005 MAX. FILLET R. TOLERANCES ON DECIMALS . XX ± .03 . XXX ± .005 ANGLES ± 1° FRACTIONS ± 1/32	DFTM. J. C. L.	TIMES MICROWAVE SYSTEMS
		DATE 8/20/03	
USED ON: -		CHKD. J. C. L.	TC-100-TM TNC MALE FOR LMR100 CABLE
		DATE 8/20/03	
SCALE: N/A	DWG. SIZE A	APPD. J. C. L.	SHEET 1 of 1
		DATE 8/20/03	
DO NOT SCALE DRAWING	CODE IDENT 68999	DATE 8/20/03	REV A