

**NOTICE OF PROPRIETARY RIGHTS** THIS DOCUMENT CONTAINS CONFIDENTIAL TECHNICAL DATA, INCLUDING TRADE SECRETS, PROPRIETARY TO TIMES MICROWAVE SYSTEMS. DISCLOSURE OF THIS DATA IS EXPRESSLY CONDITIONED UPON YOUR ASSENT THAT ITS USE IS LIMITED TO USE WITHIN YOUR COMPANY ONLY. ANY OTHER USE IS STRICTLY PROHIBITED WITHOUT THE PRIOR WRITTEN CONSENT OF TIMES MICROWAVE SYSTEMS.

SYM	REVISION DESCRIPTION	DFTM	DATE	APPD	DATE
-	RELEASED FOR PRODUCTION	J. C. L.	8/20/03	J. C. L.	8/20/03
A	CHANGED PER CDC #36704	D. J. H.	1/14/13	J. D. B.	1/15/13
B	CHANGED PER CDC #37206	J. D. B.	3/226/13	J. D. B.	3/26/13

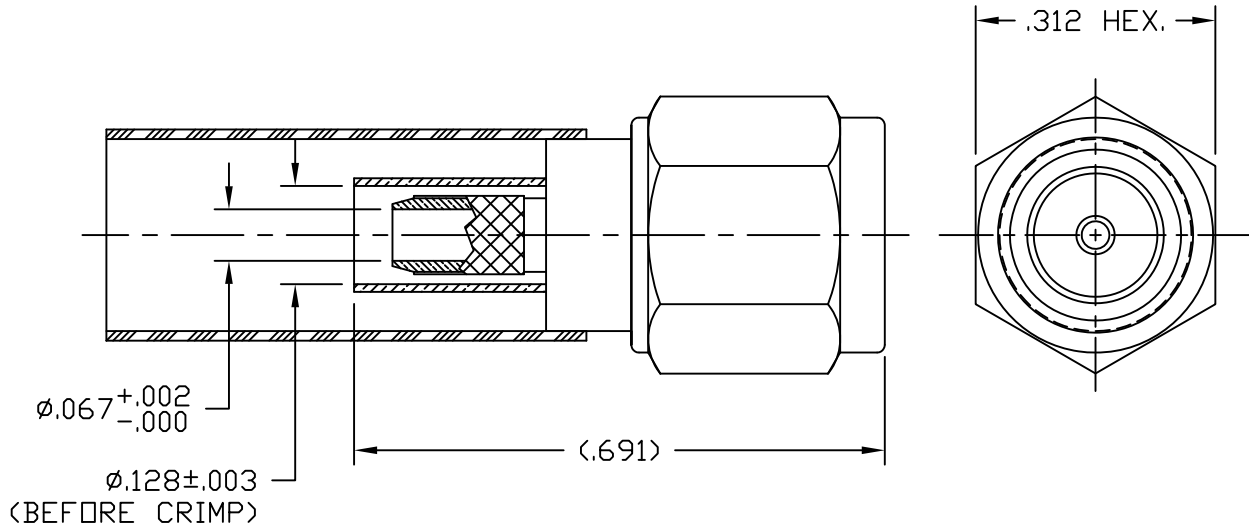

**NOTES:**

- ASSEMBLED CONNECTOR INTERFACE IS DESIGNED IN ACCORDANCE WITH MIL-STD-348.
- MATERIAL: BODY & HEX COUPLING NUT- CORROSION RESISTANT STEEL PER ASTM A582.  
CONTACT - BERYLLIUM COPPER PER ASTM B196.  
INSULATOR - TEFLON PER ASTM D1710  
GASKET - SILICONE RUBBER PER ZZ-R-765  
SHRINK SLEEVE - SHRINKABLE POLYOLEFIN PER MIL-I-23053/5  
FERRULE - D.H.P. COPPER CDA ALLOY 122
- FINISHES: BODY & HEX COUPLING NUT - PASSIVATE PER QQ-P-35  
CONTACT - GOLD PLATE PER MIL-G-45204  
FERRULE - SULFAMATE NICKEL PLATE
- CONTACT PIN IS SOLDERED.
- CRIMP THE FERRULE TO .128" HEX.

**Australian Representatives**  
**ROJONE, PTY LTD.**  
 Tel: 02 9829 1555  
 E: sales@rojone.com.au  
 www.rojone.com.au

MATERIAL:	UNLESS OTHERWISE SPECIFIED		DFTM. J. C. L.	TIMES MICROWAVE SYSTEMS	
	ALL DIMENSIONS ARE IN INCHES MACHINED SURFACES FINISH N/A RMS MAX. REMOVE ALL BURRS .005 MAX. BREAK MACHINE CORNERS .005 MAX. FILLET R. TOLERANCES ON DECIMALS . XX ± .03 . XXX ± .005 ANGLES ± 1° FRACTIONS ± 1/32		DATE 8/20/03		
USED ON: A			CHKD. J. C. L.	<b>TC-100-SM</b> SMA MALE FOR LMR100 CABLE	
			DATE 8/20/03		
SCALE: N/A	DWG. SIZE A	DO NOT SCALE DRAWING	CODE IDENT 68999	DATE 8/20/03	SHEET 1 of 1
					REV B