

NON MAGNETIC RIGHT ANGLE PLUG CRIMP TYPE

R110.170.147

CABLE 2/50S

Series : MMCX

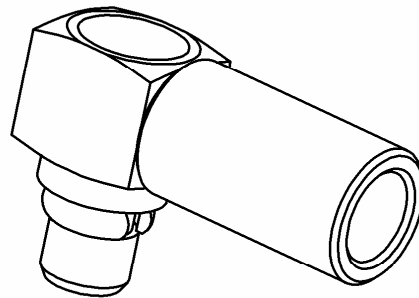
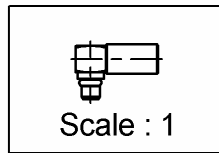
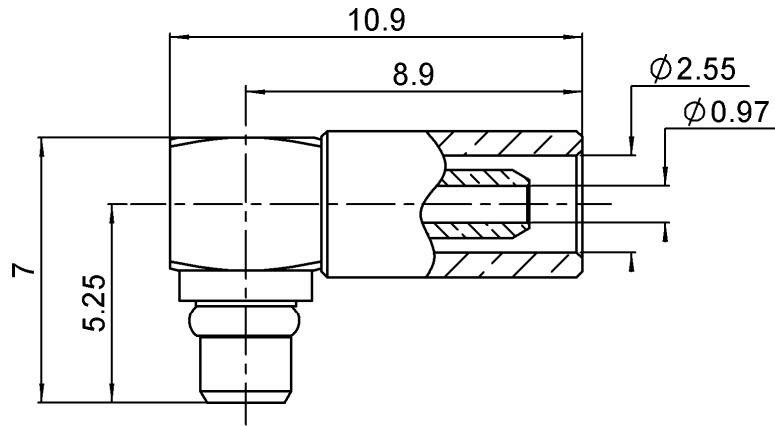

All dimensions are in mm.

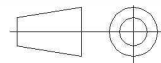

COMPONENTS	MATERIALS	PLATING (µm)
BODY	NON MAGNETIC BRONZE	BBR
CENTER CONTACT	NON MAGNETIC BRONZE	GOLD OVER COPPER
OUTER CONTACT	-	-
INSULATOR	PTFE	-
GASKET	-	-
OTHERS PARTS	BRONZE, BERYLLIUM COPPER	BBR, GOLD OVER COPPER
-	-	-
-	-	-

Australian Representatives
ROJONE, PTY LTD.
 Tel: 02 9829 1555
 E: sales@rojone.com.au
 www.rojone.com.au

Issue : 1021 A

In the effort to improve our products, we reserve the right to make changes judged to be necessary.



PRELIMINARY

NON MAGNETIC RIGHT ANGLE PLUG CRIMP TYPE

R110.170.147

CABLE 2/50S

Series : MMCX

PACKAGING

Standard	Unit	Other
100	'W' option	Contact us

SPECIFICATION

ELECTRICAL CHARACTERISTICS

Impedance		50 Ω
Frequency		0-6 GHz
VSWR	1.35 +	0,0000 x F(GHz) Maxi
Insertion loss		0.1 √F(GHz) dB Maxi
RF leakage	- (NA - F(GHz)) dB Maxi
Voltage rating		170 Veff Maxi
Dielectric withstanding voltage		500 Veff mini
Insulation resistance		1000 MΩ mini

CABLE ASSEMBLY

Stripping	a	b	c	d	e	f
mm	1,40	6,35	9,00	0,00	7,60	0,00

Assembly instruction : **Crimp 05**

Recommended cable(s)

**NON MAGNETIC CABLE
RG 178 AMAG**

Characteristics indicated on this data sheet are those that can be achieved with the highest performance cable. Intrinsic limitations of the cable may diminish the performance of the assembly

Cable retention

- pull off **32** N mini
- torque **NA** N.cm

MECHANICAL CHARACTERISTICS

Center contact retention		
Axial force – Mating end	10	N mini
Axial force – Opposite end	10	N mini
Torque	NA	N.cm mini

TOOLING

Part Number	Description	Hexagon
.	.	.
R282.211.000	CRIMPING TOOL	3.25
R282.235.003	CRIMPING DIES M22520/5-03	3.25
R282.293.000	CRIMPING TOOL M22520/5-01	

Recommended torque		
Mating	NA	N.cm
Panel nut	NA	N.cm
Clamp nut	NA	N.cm
A/F clamp nut	0,0000	mm

Mating life	500	Cycles mini
Weight	0,8700	g

OTHER CHARACTERISTICS

Distortion of the magnetic field
<0.5 ppm at 10mm at B₀ = 1.5 Tesla
Non magnetic component
RADIALL PAQ-C-007

ENVIRONMENTAL

Operating temperature	-55/+155	° C
Hermetic seal	NA	Atm.cm3/s
Panel leakage	NA	

Issue : 1021 A

In the effort to improve our products, we reserve the right to make changes judged to be necessary.



PRELIMINARY

NON MAGNETIC RIGHT ANGLE PLUG CRIMP TYPE

R110.170.147

CABLE 2/50S

Series : MMCX

COMPONENTS

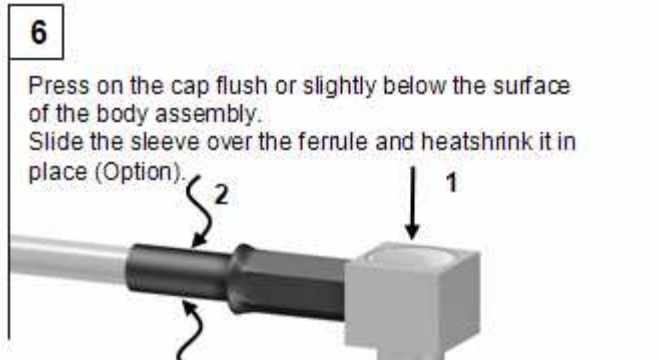
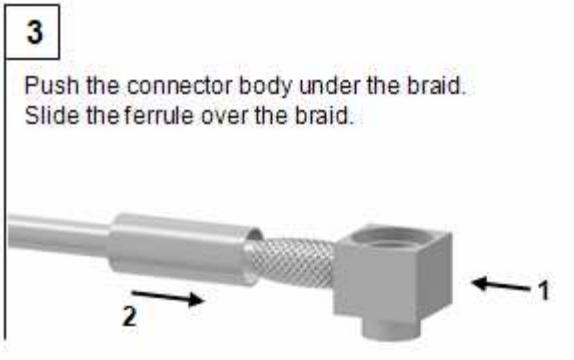
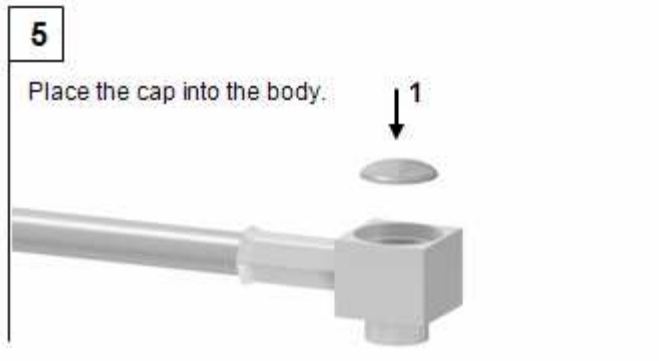
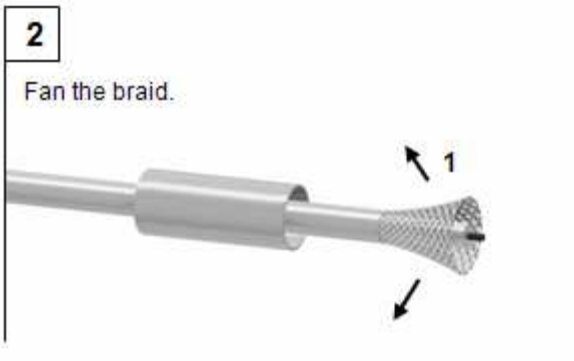
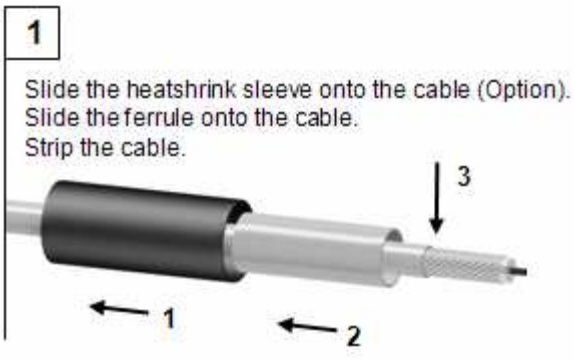
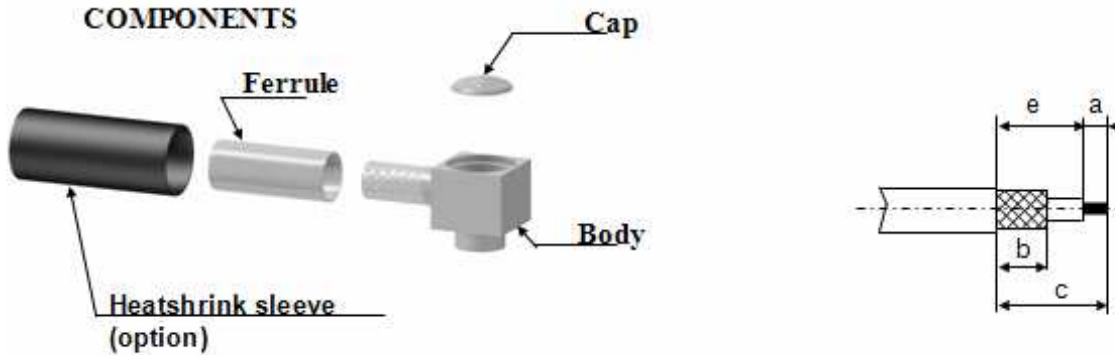

Issue : 1021 A

In the effort to improve our products, we reserve the right to make changes judged to be necessary.



PROHIBITED