

RIGHT ANGLE H3 RECEPTACLE SMT TYPE

R107.303.040

BOBINE 100

Series : UMP

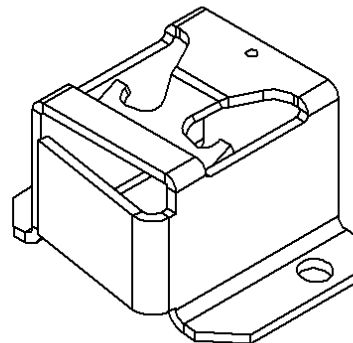
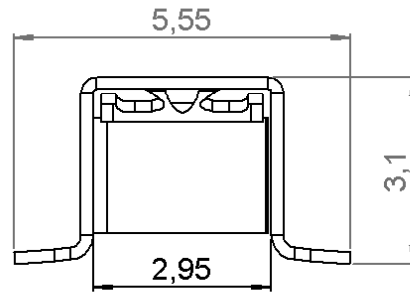
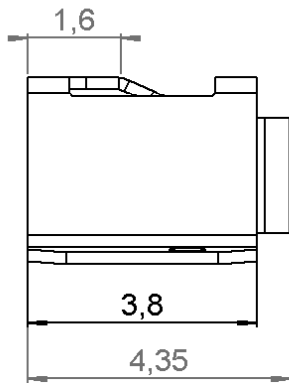
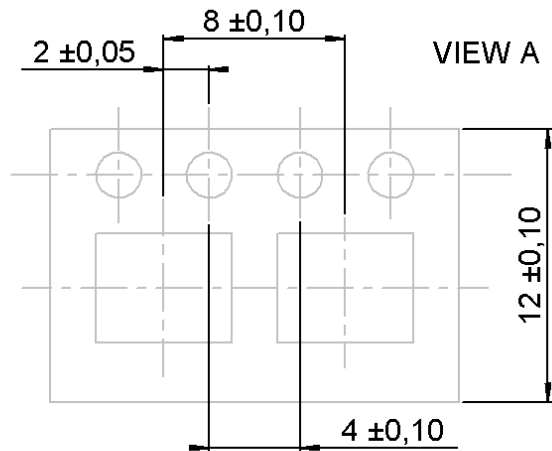
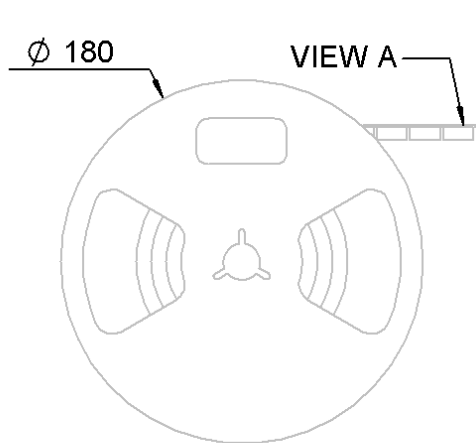

SCALE: 1/1

All dimensions are in mm.



COMPONENTS	MATERIALS	PLATINGS (µm)
BODY	BERYLLIUM COPPER	GOLD 0.2 OVER NICKEL 2
CENTER CONTACT	-	-
OUTER CONTACT	-	-
INSULATOR	-	-
GASKET	-	-
OTHERS PARTS	-	-
-	-	-
-	-	-



Australian Representatives
ROJONE, PTY LTD.
 Tel: 02 9829 1555
 E: sales@rojone.com.au
 www.rojone.com.au

Issue : 1213 C

In the effort to improve our products, we reserve the right to make changes judged to be necessary.



RIGHT ANGLE H3 RECEPTACLE SMT TYPE

R107.303.040

BOBINE 100

Series : UMP

PACKAGING

SPECIFICATION

Standard	Unit	Other
100	'W' option	Contact us

ELECTRICAL CHARACTERISTICS

ENVIRONMENTAL

Impedance	50	Ω
Frequency	0-6	GHz
VSWR	1.05 + 0,0300	x F(GHz) Maxi
Insertion loss	NA	\sqrt{F} (GHz) dB Maxi
RF leakage	NA	- F(GHz)) dB Maxi
Voltage rating	100	Veff Maxi
Dielectric withstanding voltage	350	Veff mini
Insulation resistance	1000	M Ω mini

Operating temperature	-40/+125	$^{\circ}$ C
Hermetic seal	NA	Atm.cm3/s
Panel leakage	NA	

OTHERS CHARACTERISTICS

Assembly instruction

Others :

MECHANICAL CHARACTERISTICS

Center contact retention		
Axial force – Mating end	-	N mini
Axial force – Opposite end	-	N mini
Torque	-	N.cm mini
Recommended torque		
Mating	-	N.cm
Panel nut	-	N.cm
Mating life	50	Cycles mini
Weight	0,0600	g

Issue : 1213 C

In the effort to improve our products, we reserve the right to make changes judged to be necessary.



RIGHT ANGLE H3 RECEPTACLE SMT TYPE

R107.303.040

BOBINE 100

Series : UMP

**SOLDER PROCEDURE OF UMP RECEPTABLE
IN INDUSTRIAL ENVIRONMENT**

1. Deposit solder paste 'Sn Ag4 Cu0.5' on mounting zone by screen printing application. We recommend a low residue flux.
We advise a thickness of 150 micromm (5.850 microinch). Verify that the edges of the zone are clean.
2. Placement of the receptacle on the mounting zone with an automatic machine of 'pick and place' type. A video camera is recommended for positioning of the component . Adhesive agents must not be used on the receptacle.
3. This process of soldering has been tested with convection oven .Below please find ,the typical profile to use.
4. The cleaning of printed circuit boards is not obliged .
5. Verification of solder joints and position of the component by visual inspection.

NOTE : The UMP receptacle and the UMP plug must not be mated before completion of this procedure

TEMPERATURE PROFILE

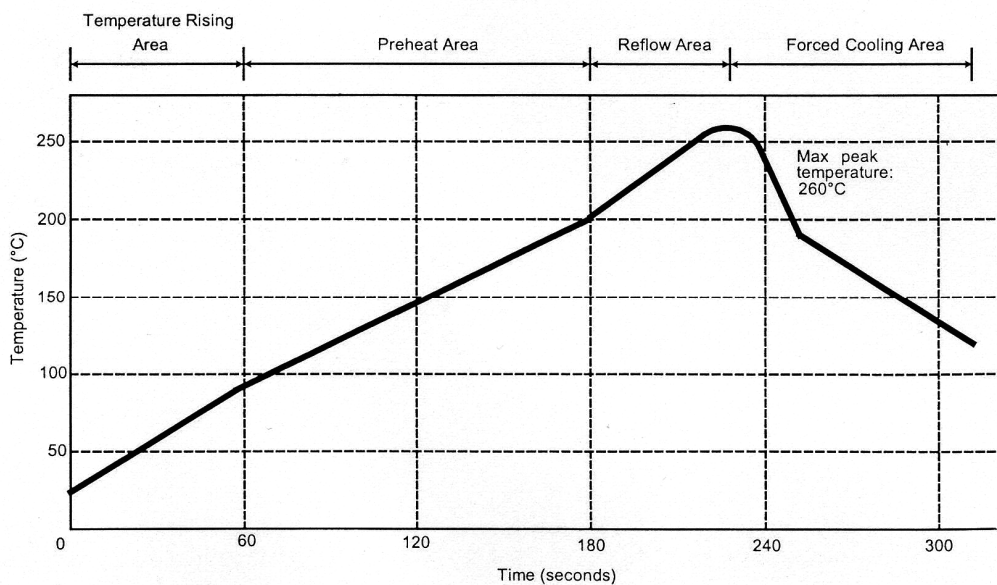

Parameter	Value	Unit
Temperature rising Area	1 - 4	°C/sec
Max Peak Temperature	260	°C
Max dwell time @260°C	10	sec
Min dwell time @235°C	20	sec
Max dwell time @235°C	60	sec
Temperature drop in cooling Area	-1 to - 4	°C/sec
Max dwell time above 100°C	420	sec

Issue : 1213 C

In the effort to improve our products, we reserve the right to make changes judged to be necessary.



RIGHT ANGLE H3 RECEPTACLE SMT TYPE

R107.303.040

BOBINE 100

Series : UMP



UMP SERIES INFORMATION

PCB

COPLANAR LINE

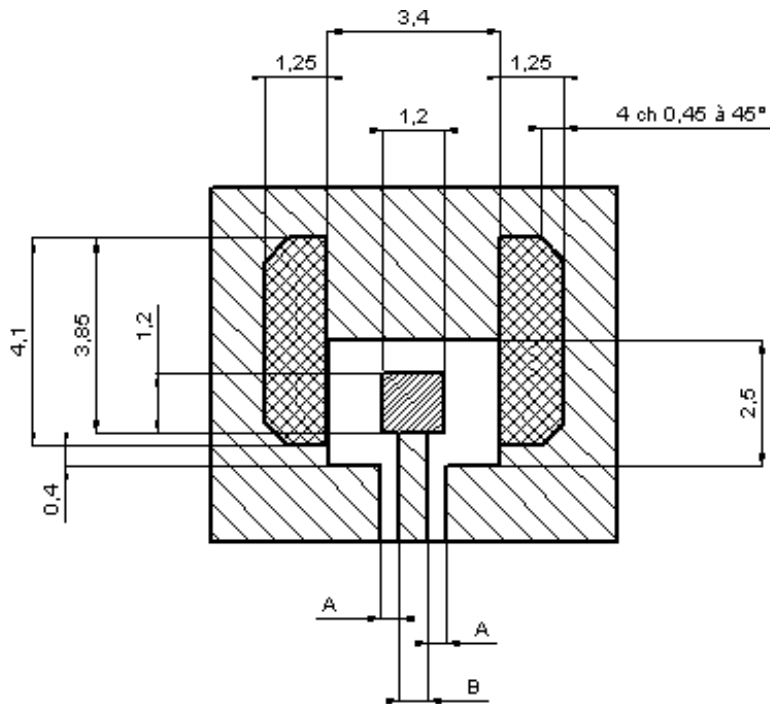
Ground and signal are on the same side
 The material of PCB is glass is glass-epoxy Composite.



-  Gold over nickel for solder paste
-  Gold over nickel contact area free of any surface contaminant
-  Ground + varnish

APPLICATION 75Ω
 WITH B = 0,55mm

PCB thickness (mm)	Coplanar ligne A (mm)
0,8	0,57
1,0	0,45
1,2	0,41
1,6	0,37

APPILCATION 50Ω
 WITH B = 1,2mm

PCB thickness (mm)	Coplanar ligne A (mm)
0,8	0,183
1,0	0,190
1,2	0,195
1,6	0,20

Issue : 1213 C

In the effort to improve our products, we reserve the right to make changes judged to be necessary.



RIGHT ANGLE H3 RECEPTACLE SMT TYPE

R107.303.040

BOBINE 100

Series : UMP

UMP SERIES INFORMATION

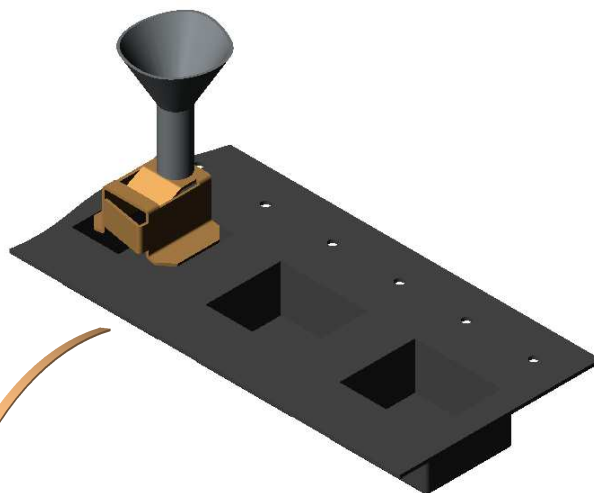
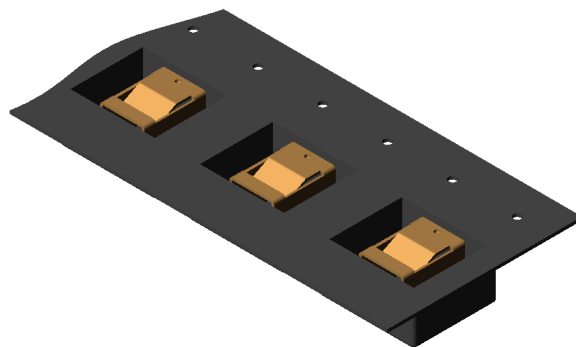
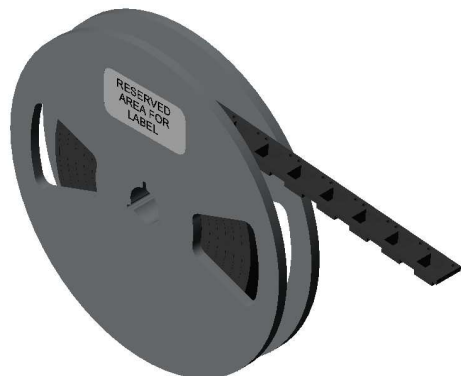

ASPIRATION PORT

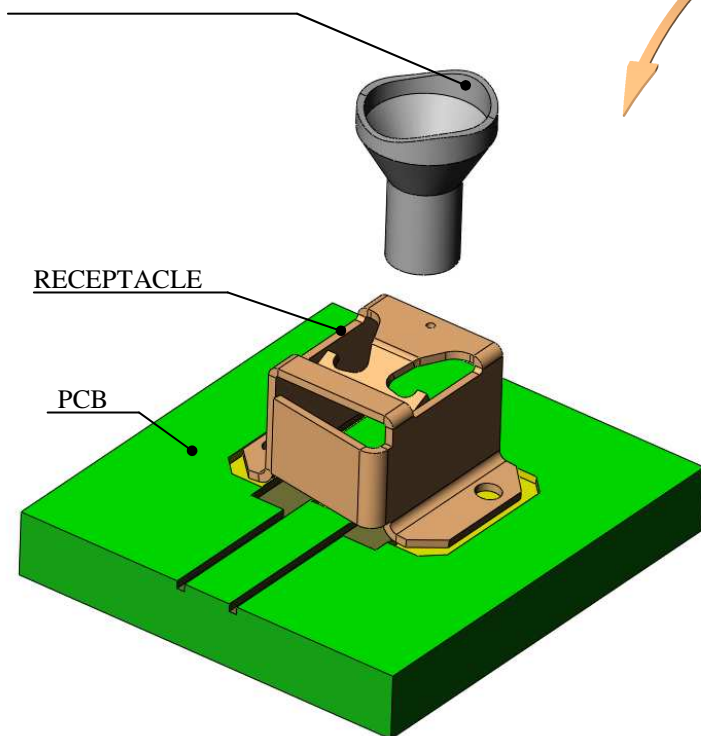

ASPIRATION PORT

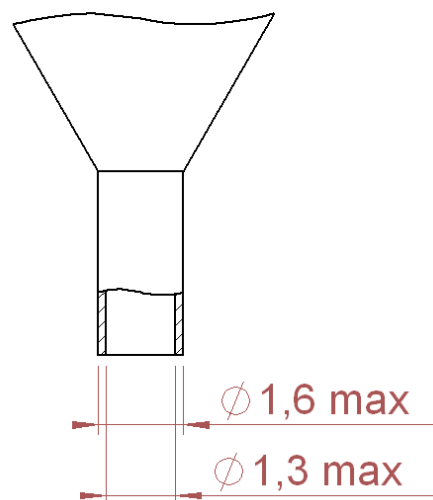

Issue : 1213 C

In the effort to improve our products, we reserve the right to make changes judged to be necessary.



RIGHT ANGLE H3 RECEPTACLE SMT TYPE

R107.303.040

BOBINE 100

Series : UMP

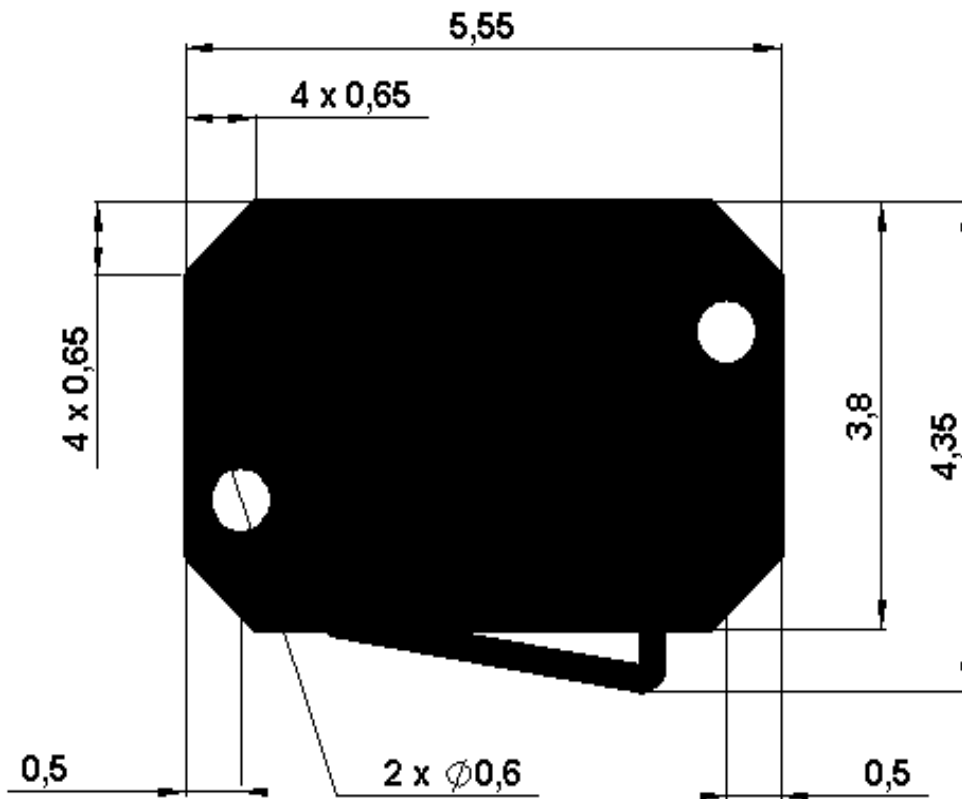

SHADOW FOR VIDEO CAMERA

ASPIRATION AREA

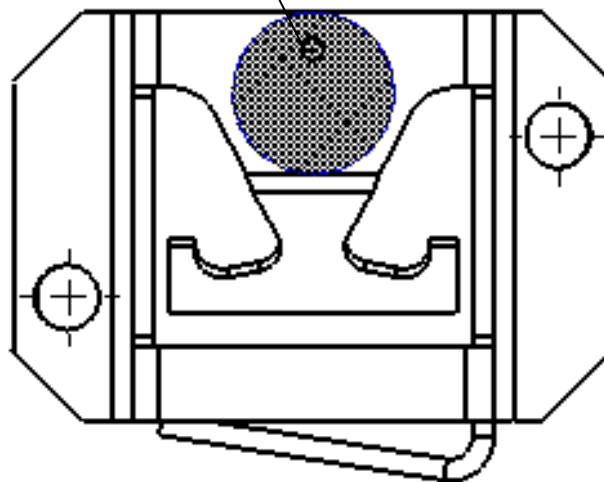

Issue : 1213 C

In the effort to improve our products, we reserve the right to make changes judged to be necessary.



RIGHT ANGLE H3 RECEPTACLE SMT TYPE

R107.303.040

BOBINE 100

Series : UMP

UMP CONNECTING NOTE

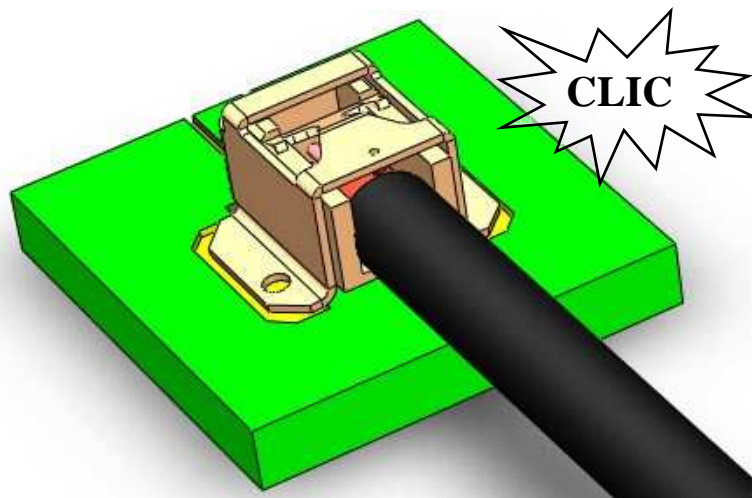
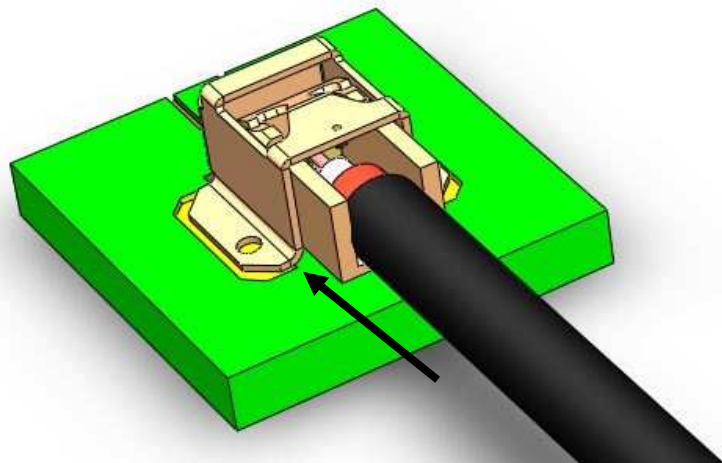
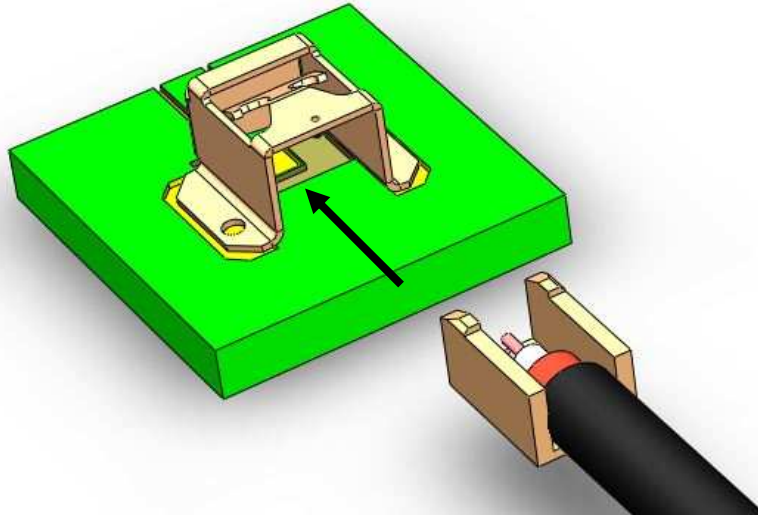

Issue : 1213 C

In the effort to improve our products, we reserve the right to make changes judged to be necessary.



RADIALL®

RIGHT ANGLE H3 RECEPTACLE SMT TYPE

R107.303.040

BOBINE 100

Series : UMP

UMP CONNECTING NOTE

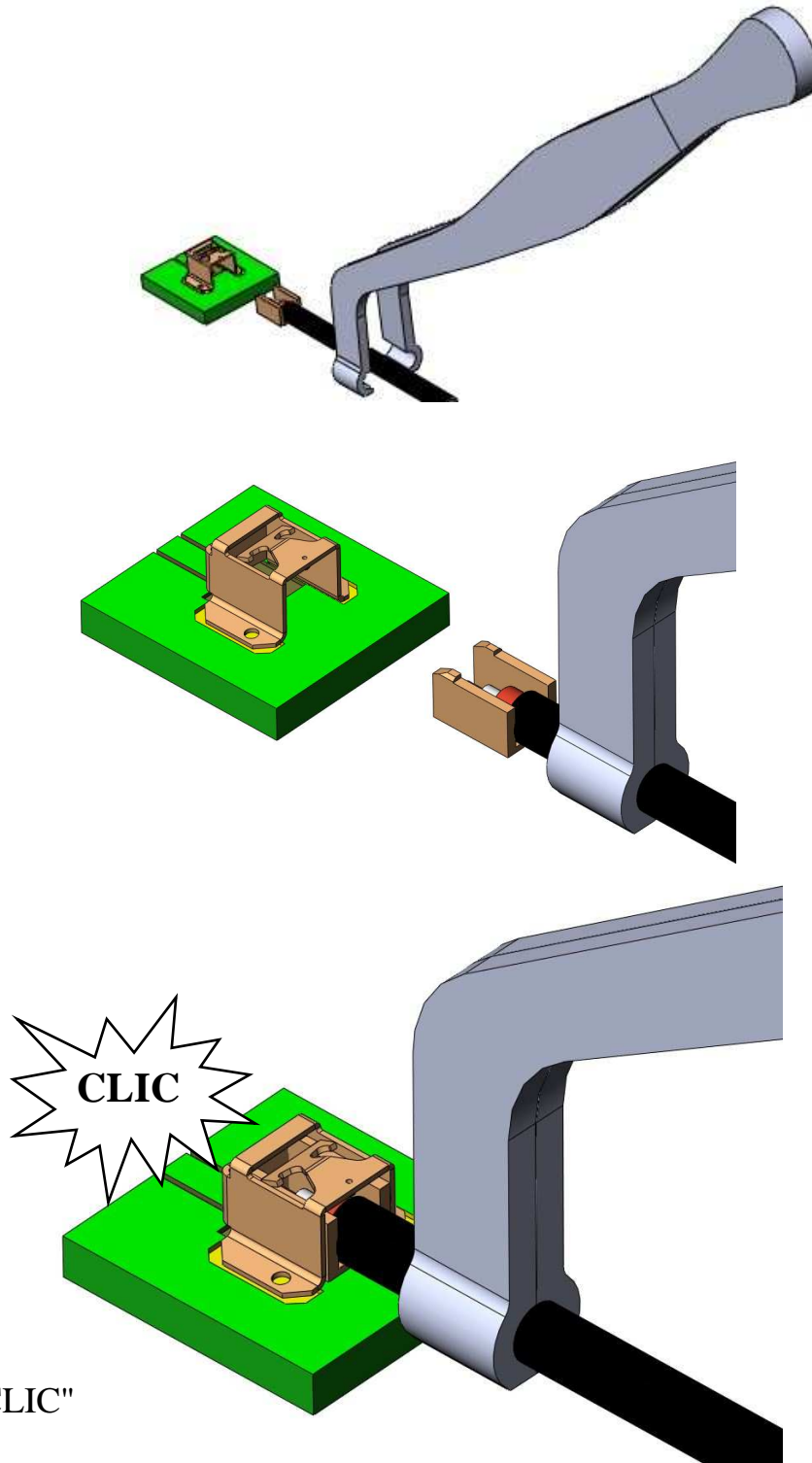

Issue : 1213 C

In the effort to improve our products, we reserve the right to make changes judged to be necessary.



RIGHT ANGLE H3 RECEPTACLE SMT TYPE

R107.303.040

BOBINE 100

Series : UMP

UMP DISCONNECTING NOTE

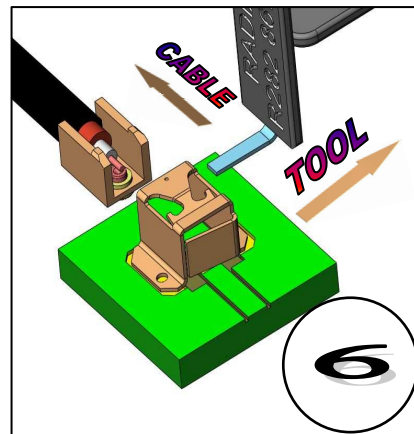
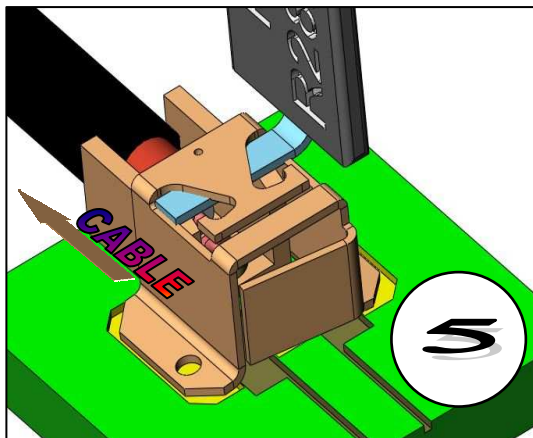
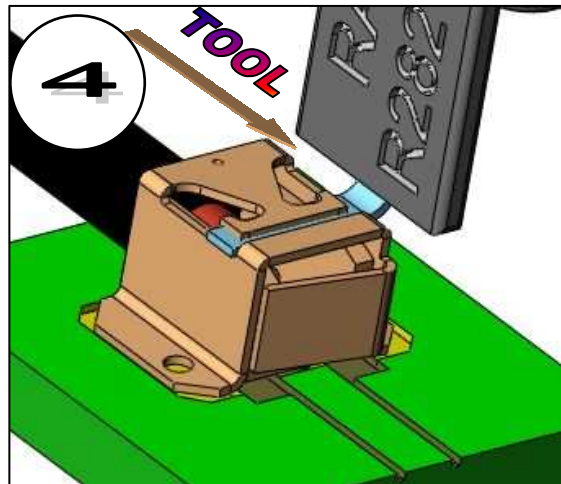
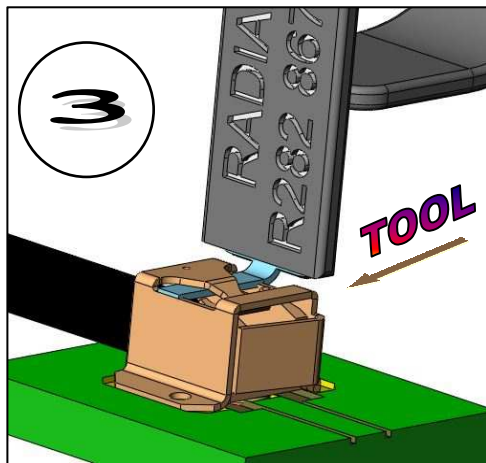
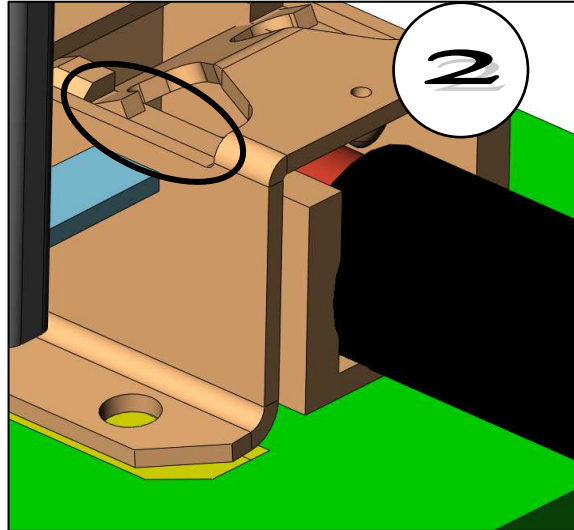
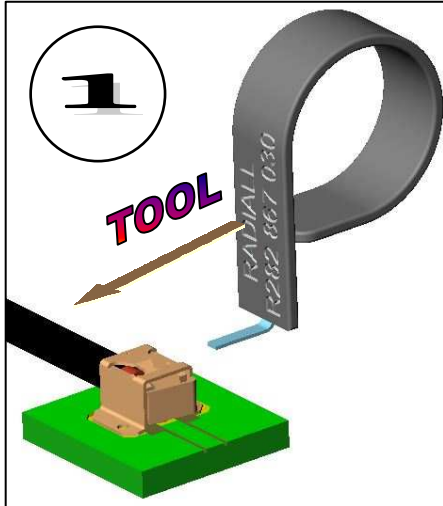

Issue : 1213 C

In the effort to improve our products, we reserve the right to make changes judged to be necessary.