

**NOTICE OF PROPRIETARY RIGHTS** THIS DOCUMENT CONTAINS CONFIDENTIAL DATA, INCLUDING TRADE SECRETS, PROPRIETARY TO TIMES MICROWAVE SYSTEMS. DISCLOSURE OF THIS DATA IS EXPRESSLY CONDITIONED UPON YOUR ASSENT THAT ITS USE IS LIMITED TO USE WITHIN YOUR COMPANY ONLY. ANY OTHER USE IS STRICTLY PROHIBITED WITHOUT THE PRIOR WRITTEN CONSENT OF TIMES MICROWAVE SYSTEMS.

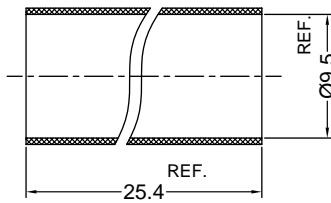

**Australian Representatives**  
**ROJONE, PTY LTD.**  
 Tel: 02 9829 1555  
 E: sales@rojone.com.au  
 www.rojone.com.au

SYM	REVISION DESCRIPTION	DFTM	DATE	APPD	APPD
A	RELEASED FOR PRODUCTION	Joslen	2015.05.14	TZ	2015.05.14

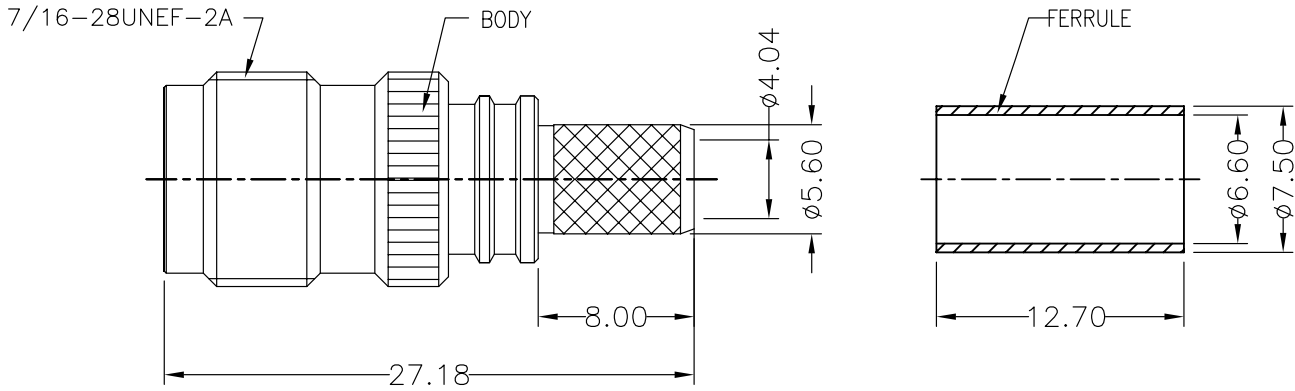

Heat Shrink Tube

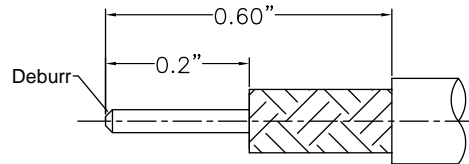

RECOMMENDED CABLE STRIPPING DIM'S  
 Connector adds: 12.5 mm

**I. MATERIALS & FINISHES**

Components	Materials	Finishes	Thk. (μ")
Body	Brass	Albaloy	80
Center Cont.	QBe 2	Gold	50
Insulator	PTFE	--	--

**II. ELECTRICAL PROPERTIES**

Impedance (Ω):	50
Frequency Range (GHz):	DC to 6 GHz
Working Voltage (V):	1000
Insulation Resistance (MΩ):	≥5000
VSWR:	≤1.30
Insertion Loss(dB, f/GHz):	-0.1x √f

**III. ENVIRONMENT PROPERTIES**

Temperature Range:	-55°C~+85°C
Thermal Shock:	MIL-STD 202G, Meth.107, Cond.B
Vibration:	MIL-STD 202G, Meth.204, Cond.B
Shock:	MIL-STD 202G, Meth.213, Cond I
Climatic Class:	IEC 60068 55/155/56
(2002/95/EC)RoHS:	Compliant

**IV. MECHANICAL PROPERTIES**

Center Cont.:	Captive
Outer Cont.:	Crimp
Coupling Nut Torque (N.m):	N/A
Cbl-Connector Retention Force (N):	500
Climatic Class:	IEC 60068 55/155/56
Durability (cycles):	500

**V. TOOLING**

Stripping Tool: 3192-152/CST-240A  
 Crimping Tool: 3190-667/CT-240/200/100

MATL:	UNLESS OTHERWISE SPECIFIED		DFTM.	Joslen	<b>TIMES MICROWAVE SYSTEMS</b>			
	ALL DIMENSIONS ARE IN mm MACHINED SURFACES FINISH 1.6 RMS MAX. REMOVE ALL BURRS 0.15X45° MAX. BREAK MACHINE CORNERS 0.15X45° D MAX. FILLET R. TOLERANCES ON DECIMALS .X ±0.3 .XX ±0.15 ANGLES ±2° FRACTIONS ± N/A		DATE	2015.05.14				
			CHKD	KG				
			DATE	2015.05.14				
USED ON: O			APPD	TZ	<b>EZ-240-TF-RP-X</b> Reversed Polarity TNC Female (Male Pin) Straight Non-Solder Pin No Braid Trim Connector for LMR-240 Cable			
SCALE: N/A	DWG SIZE: A4	DO NOT SCALE DRAWING	CODE IDENT	68999	DATE: 2015.05.14	SHT: 1 OF 1	<b>3190-6167</b>	REV: A